

YCAA-B AIR COOLED LIQUID CHILLER

R407C REFRIGERANT

COOLING CAPACITIES 46 kW to 152 kW



York YCAA-B twin refrigerant circuit air cooled liquid chillers are a compact design suitable for chilled water or glycol cooling.

YCAA-B units are available in three versions: YCAA-B (standard); YCAA-B LN (low noise operation) and YCAA-B HT (high temperature operation). YCAA-B models 60 - 150 of all three versions are available with either user friendly standard control or optional York Integrated System Network (ISN) control. YCAA-B models 170 - 210 are fitted with York ISN control as standard.

YCAA-B units are designed to be located outside on the roof of a building or at ground level. The units can be converted into total cooling plants with the field mounted Hydro Kit option.

AVAILABLE MODELS & NOMINAL COOLING CAPACITIES TABLE 1

Model	YCAA-B (Standard)								
	60	75	L90	L105	120	150	170	190	210
Cooling Capacity (kW)	46.2	53.0	62.9	72.6	88.2	100.5	122.2	135.3	148.6

Model	YCAA-B LN (Low Noise)								
	60	75	L90	L105	120	150	170	190	210
Cooling Capacity (kW)	47.9	53.4	64.3	70.1	89.8	102.3	118.9	135.6	143.5

Model	YCAA-B HT (High Temperature)								
	60	75	L90	L105	120	150	170	190	210
Cooling Capacity (kW)	49.6	57.1	67.8	77.6	95.6	109.0	124.0	142.9	151.7

Cooling capacities at 7°C leaving chilled liquid temperature and 35°C condenser air entering temperature.

CONTENTS

Specification

Accessories and Options

Controls

Operating Limitations

Refrigeration Flow Diagram

Selection Guide

Water Pressure Drops

Cooling Capacities

Glycol Selection Guide

Glycol Cooling Capacities

Sound Power Spectrum

Physical Data

Electrical Data

Electrical Connections

Dimensions

Space Requirements

FEATURES

FEATURES	BENEFITS
Two refrigerant circuits.	System stand-by security.
Minimum base area/maximum capacity.	Minimum installation space.
Low weight , single power and control supplies.	Easy to install.
Full factory run test.	Operating quality control.
Accessible components.	Ideal for maintenance operations
Residual current circuit breaker.	Operator safety.
Microprocessor control with visual display of temperatures and alarms.	Simple operation.
Manufactured to ISO 9001/EN 29001.	High standard of quality control.

SPECIFICATION

The chillers shall be completely factory assembled with all interconnecting refrigerant piping and wiring ready for field installation. After assembly the YCAA-B shall have a full test run with water flowing through the evaporators. The YCAA-B shall be pressure tested, evacuated and fully charged with refrigerant and include an initial oil charge.

YCAA-B LN (Low Noise Version)

Very low noise levels are achieved on YCAA-B LN units without any impact on unit performance or operating limits. The noise reduction is obtained using greater surface area condenser coils and special fan configuration. In addition, on models 60 - 150, the compressor compartment is completely acoustically insulated. Mufflers are mounted on the compressor discharge lines of all models and each compressor is also separately enclosed in an acoustic sound blanket.

YCAA-B HT (High Temperature Version)

YCAA-B HT units are suitable for operation at higher ambient temperatures. The higher ambient limit is obtained using greater surface area condenser coils and high efficiency fans.

The unit structure shall be of heavy gauge galvanised steel fastened with stainless steel screws and bolts. Galvanised steel parts shall be painted with baked-on powder paint (Desert Sand (RAL 1019)).

Compressors

YCAA-B models 60-75-120-150 shall have two hermetic reciprocating compressors with internal motor protection housed in a separate acoustically lined enclosure.

YCAA-B models L90-L105-170-190-210 shall have scroll compressors.

Compressors on all models shall be mounted on rubber anti-vibration pads and have direct on line starting.

The compressor motors shall be refrigerant gas cooled, with integral thermistor protection against overloads. The overload protection is automatically reset after approximately 8 seconds.

The motor terminal boxes shall have IP-54 weather protection.

The compressors shall be switched On and Off by the unit microprocessor to provide capacity control.

Evaporators

The evaporators shall be a stainless steel plate type heat exchangers thermally insulated with flexible closed cell material. Design working pressure shall be 10 bar g on the water side and 30 bar g on the refrigerant side. An electric heater mat and evaporator differential pressure switch shall be provided for freeze protection.

The evaporators shall have a common water manifold for single flow and return water connections. Water connection to the manifold shall be via 2 inch gas connections. A bleed valve shall also be provided on the manifold.

Refrigerant Circuits

Two refrigerant circuits shall be provided and each circuit shall include: service valves for refrigerant charging, discharge and liquid line isolating valves, a sight glass with moisture indicator, a filter dryer and a thermostatic expansion valve.

On models 60 - 150 high and low pressure switches shall also be provided.

On models 170 - 210 transducers and switches shall be included on the high pressure circuits and transducers shall be provided on the low pressure circuits.

Air Cooled Condensers

The condenser coils shall be seamless copper tubes, arranged in staggered rows, mechanically expanded into corrugated aluminium fins. Design working pressure of the coils shall be 28 bar g.

All YCAA-B models shall have a stepless fan speed controller fitted as standard. When standard control is fitted, the controller operates on the basis of ambient air temperature allowing operation down to -5°C ambient air temperature. When ISN control is fitted, the controller operates on the basis of condensing pressure with operation possible down to -18°C ambient air temperature.

The condenser fans shall be direct drive with aluminium aerofoil blades. Each fan will have a painted galvanised steel protection guard. The totally enclosed fan motors shall have IP-54 weather protection and thermocontact protection embedded in their windings.

Power and Control Panel

All controls and motor starting equipment necessary for full unit operation shall be factory wired and tested.

Power and control components are accessed via individual doors on YCAA-B models 60 to 150.

The control compartment shall contain an electronic circuit board and a soft touch key control panel with display of operating functions, alarms and stops.

The power compartment shall have a door interlocked isolator and shall contain compressor and fan contactors, fuses and supply protection.

ACCESSORIES AND OPTIONS

Integrated System Network (ISN) Control

A York Integrated System Network (ISN) control is fitted as standard on YCAA-B models 170 - 210 and is available as an option on models 60 - 150. The ISN control offers Building Management System (BMS) communication, leaving chilled liquid temperature or entering chilled liquid temperature control, sequence control, double setpoint, display and print of unit operational and history data alarm history.

ISN Control - EMS Offset Card (Temperature Reset/Offset)

Additional PCB allowing alternative signals to be used from customer EMS to unit controls to perform remote liquid leaving temperature setpoint reset/offset function. Suitable for water and glycol control ranges (cannot be fitted when a sequence control is fitted).

ISN Control - Hand Held Printer

Hand held printer with internal NiCad battery and "D" type connector to allow print out of unit operational and history data. Battery charger is included for 220/240 Vac supply.

ISN Control - Sequence and Automatic Lead/Lag Control

Sequencing control centre to manage sequencing control of up to eight units in parallel based on mixed liquid temperature, interconnecting wiring by others (cannot be fitted when an EMS offset card is fitted).

Remote On/Off Kit (YCAA-B 60 - 150 Standard Control only)

The kit allows remote activation of the cooling mode when the YCAA-B unit is in stand-by.

The kit contains a remote control with 3 metre cable for wall mounting, additional PCB for LED control and full installation instructions.

230 V - 3Ø - 50 Hz Supply

YCAA-B models 75, 105 and 150 with standard control can be supplied for use with 230 V - 3Ø - 50 Hz.

Hydro Kit

The field installed York Hydro Kit is a hydraulic package complete with all components required for the correct operation of a liquid distribution circuit. The Hydro Kit can be combined directly on YCAA-B models 60 - 150 or remotely on all models.

The Hydro Kit is fully enclosed and comprises: a buffer tank, pump(s), expansion tank(s), filter, pressure gauge, shut-off valves, safety valve, automatic vent valve, drain valve, charge valve, safety valve for system discharge and electrical panel.

Flow Switch

Supplied loose for field installation by contractor.

Water filter

A field mounted water filter for fitting in the customers water circuit.

Anti-vibration Mounts

Open spring isolator mounts with fixing down holes, for field installation.

High Pressure Fans (only available on Standard Units with ISN Control)

Alternative fans suitable for external static pressures up to 80 Pa.

Condenser Coil Protection

Copper fins, Blue fins (pre-coated aluminium condenser fins for corrosion resistance in mild seashore locations - corrosion resistance (salt spray test as per ASTM B117): minimum 300 hours).

Condenser Coil Guards

Painted galvanised steel wire guards mounted on the unit exterior.

Gauge Kit (YCAA-B 60 - 150 Standard Control only)

Factory fitted mechanical dial gauges for suction and discharge pressure indication of each refrigerant circuit.

STANDARD CONTROL (YCAA-B 60 - 150 only)

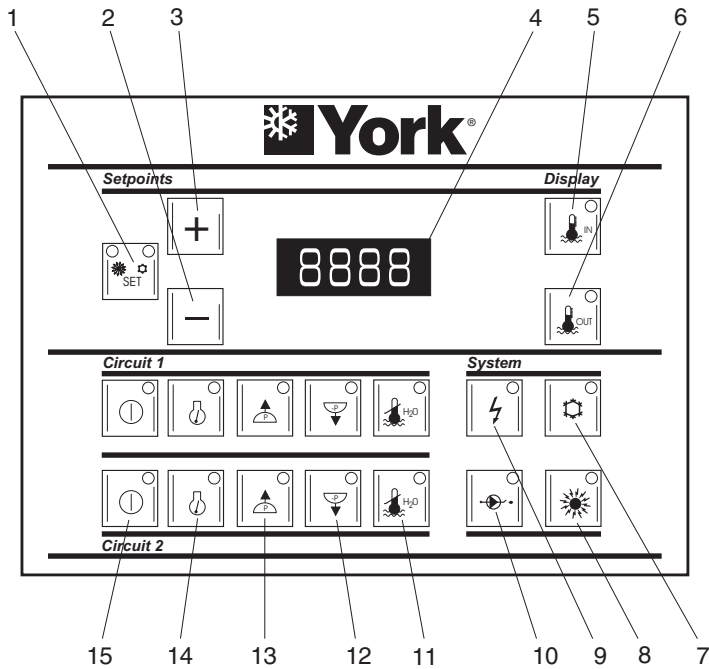

Standard Control Panel

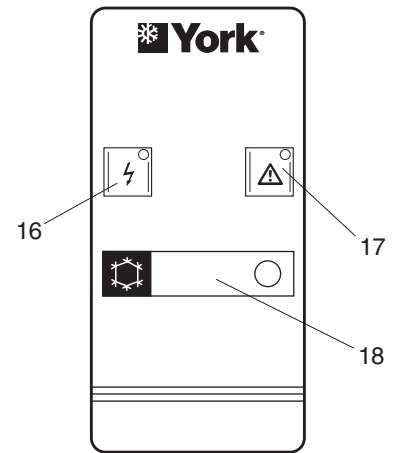

Remote On/Off Panel (Optional)

- 1 Setpoint selection and display key and LED
- 2 Setpoint change key (-). Decreases desired water temperature.
- 3 Setpoint change key (+). Increases desired water temperature.
- 4 Display
- 5 Inlet water display and LED.
- 6 Outlet water display and LED.
- 7 Start key and LED - Cooling.
- 8 Not used.
- 9 Voltage ON LED.

- 10 External interlock alarm LED.
- 11 Antifreeze alarm.
- 12 Low pressure alarm LED.
- 13 High pressure alarm LED.
- 14 Compressor ON LED.
- 15 Start-up key and LED.
- 16 Voltage ON LED.
- 17 Unit alarm activated LED.
- 18 Start key and LED - Cooling.

ISN CONTROL (Standard YCAA-B 170 - 210, optional YCAA-B 60 - 150)

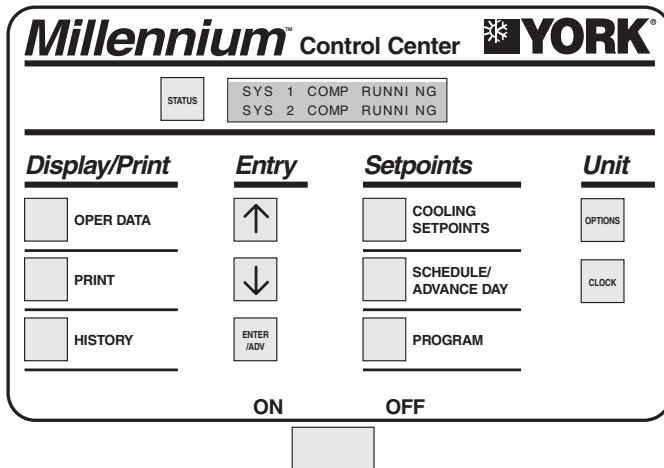

ISN Millennium™ Control Center Panel

The panel shall contain:

- A 40 character Liquid Crystal Display (LCD) with Light Emitting Diode (LED) back lighting for outdoor viewing.
- A Colour coded 12-button keypad.
- Customer terminal block for control inputs and liquid flow switch.

The microprocessor control will include:

Status Key for display of:

- Status of the unit and each refrigerant circuit
- System and unit safety fault messages

Display/Print Keys for display of:

- Chilled liquid and ambient air temperatures
- System pressures (each circuit)
- Operating hours and starts (each compressor)
- Load and unload timers and cooling demand
- Liquid pump, evaporator heater and condenser fan status

Print calls up to the liquid crystal display:

- Operating data for the systems
- History of fault shutdown data for up to the last six fault shutdown conditions

An RS-232 port, in conjunction with this press-to-print button, is provided to allow hard copy print-outs via a separate printer.

Entry Keys

- To program and modify system values

Setpoints Keys for programming:

- Chilled liquid temperature setpoint and range
- Remote reset temperature range
- Set daily schedule/holiday for start/stop
- Manual override for servicing
- Cut-outs for low ambient temperature, low liquid temperature, high discharge pressure and low suction pressure
- Number of compressors and anti-recycle timer (compressor start cycle time)

Unit Keys

- To set time and unit options

Unit **ON/OFF** switch

- To activate or deactivate the unit

The microprocessor control system is capable of displaying the following:

- Return and leaving liquid temperature
- Low leaving liquid temperature cutout setting
- Low ambient temperature cutout setting
- Ambient air temperature
- Metric or Imperial data
- Discharge and suction pressure cutout settings
- System suction pressures
- System discharge pressures
- Anti-recycle timer status
- Anti-coincident system start timer condition
- Compressor run status
- No cooling load condition
- Day, date and time
- Daily start/stop times
- Holiday status
- Automatic or manual system lead/lag control
- Lead system definition
- Compressor starts & operating hours (each compressor)
- Status of evaporator heater and fan operation
- Run permissive status
- Number of compressors running
- Load & unload timer status
- Water pump status
- Liquid Temperature Reset via a YORK ISN DDC or Building Automation System (by others)

Provision shall be included for optional remote chilled liquid temperature reset.

The operating program will be stored in non-volatile memory (EPROM) to eliminate chiller failure due to AC power failure/battery discharge. Programmed setpoints shall be retained in lithium battery backed RTC memory.

TABLE 2 OPERATING LIMITATIONS

YCAA-B (R407C)				60		75		L90		L105	
				Min.	Max.	Min.	Max.	Min.	Max.	Min.	Max.
Chilled Liquid	Liquid outlet temperature	Water outlet	°C	+6 to +15							
		Brine outlet	°C	-8 to +15							
		Temperature spread	°K	3 to 8							
	Flow rate ⁽¹⁾	l/h	4970	13240	5700	15190	6440	17170	7654	20410	
	Pressure drop ⁽¹⁾	kPa	10.0	70.8	10.4	74.2	7.8	55.6	7.7	55.0	
Maximum operating pressure			bar	10							
Ambient Air	Air entering temperature	Standard control	°C	-5 to + see note (3)							
		ISN control	°C	-18 to + see note (3)							
	External static pressure	Standard fans	Pa	0							
		High pressure fans ⁽⁴⁾	Pa	80							
Recommended system chilled water volume ⁽²⁾			l	650	750	900	1100				
Minimum capacity step			%	50%							
Power supply voltage ⁽⁵⁾			V	400 V, 3 Ø, 50 Hz (nominal)							

YCAA-B (R407C)				120		150		170		190		210	
				Min.	Max.	Min.	Max.	Min.	Max.	Min.	Max.	Min.	Max.
Chilled Liquid	Liquid outlet temperature	Water outlet	°C	+6 to +15									
		Brine outlet	°C	-8 to +15									
		Temperature spread	°K	3 to 8									
	Flow rate ⁽¹⁾	l/h	9482	25280	10800	28810	13115	34910	14405	38413	16018	42713	
	Pressure drop ⁽¹⁾	kPa	8.9	63.3	10.5	74.4	14.8	105.6	16.1	114.1	19.9	141.7	
Maximum operating pressure			bar	10									
Ambient Air	Air entering temperature	Standard control	°C	-5 to + see note (3)				Not available					
		ISN control	°C	-18 to + see note (3)				-18 to + see note (3)					
	External static pressure	Standard fans	Pa	0									
		High pressure fans ⁽⁴⁾	Pa	80									
Recommended system chilled water volume ⁽²⁾			l	1300	1500	900	1000	1100					
Minimum capacity step			%	50%				20%		25%		25%	
Power supply voltage ⁽⁵⁾			V	400 V, 3 Ø, 50 Hz (nominal)									

(1) Total unit flow rate and pressure drop are given

Caution: Minimum flow rates may only be used with brine solutions after reprogramming unit parameters.

(2) Table shows minimum water / brine volume of system

(3) Maximum ambient air temperature depends on coding:

Standard/Low Noise Units: ISPESL 43°C, SDM 40°C, TUV 40°C, SAQ 38°C, UDT 43°C

High Temperature units: ISPESL 45°C, SDM 43°C

(4) High pressure fans are not available on Low Noise or High Temperature units

(5) Voltage 400V +/- 10%

YCAA-B Models 60 -150

YCAA-B Models 170 -210

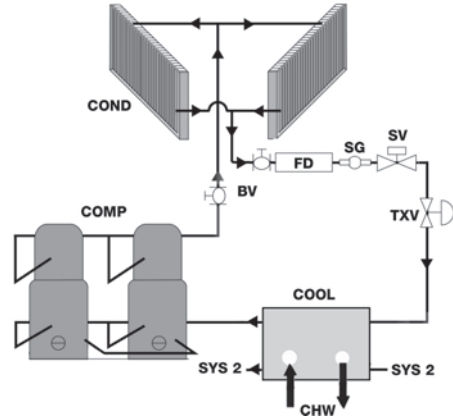
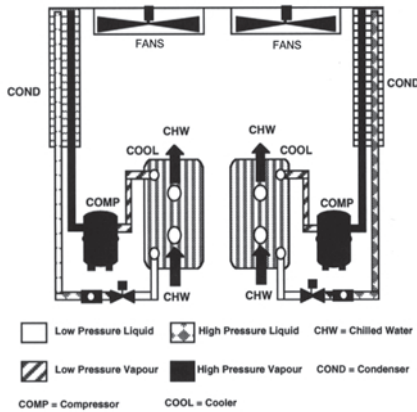

Note: Only one refrigerant circuit shown.

YCAA-B Cooling Mode

Low pressure liquid refrigerant enters the cooler (Evaporator) and is evaporated and superheated by the heat energy absorbed from the chilled water passing through the cooler plates. Low pressure vapour enters the compressor where pressure and superheat are increased. Heat is rejected via the air cooled condenser coil and fans. The fully condensed and subcooled liquid refrigerant then enters the expansion valve where pressure reduction and further cooling takes place before returning to the cooler.

SELECTION GUIDE

DATA REQUIRED

To select a YORK YCAA-B chiller the following information is required:

1. Required cooling capacity.
2. Design chilled liquid entering and leaving temperatures.
3. Design chilled liquid flow rate.
4. Design condenser entering air temperature. This will normally be the design summer ambient air temperature unless location or other factors have an influence.
5. Altitude above sea level.
6. Design Cooler fouling factor.

Note: Items 1, 2 and 3 must be linked by the following formulae:

$$\text{Cooling capacity (kW)} = \frac{\text{Flow Rate (l/h)} \times \text{Range (}^\circ\text{C)}}{860}$$

Where:

Range = Entering chilled liquid temperature - leaving chilled liquid temperature.

YCAA-B SAMPLE SELECTION

A R407C chiller is required to cool water from 13°C to 7°C having a cooling capacity of 60 kW.

Other design conditions applying are:

- Ambient air entering condenser: 35°C
- Fouling factor: 0.044 m² °C/kW
- Altitude: Sea level

From a cursory examination of capacity Table 5 a model YCAA-B 90 gives approximately the required capacity of 60.0 kW.

No correction factors, for fouling factor or altitude, apply therefore the conditions will be as follows:

- Cooling capacity: 60.0 kW
- Total unit input power: 26.3 kW
- Water temperature: 13 °C to 7 °C
- Water flow rate: $\frac{60.0 \times 860}{6} = 8600 \text{ l/h}$

Cooler pressure drop = 14 kPa (see Figure 2).

YCAA-B WATER PRESSURE DROPS

FIGURE 2

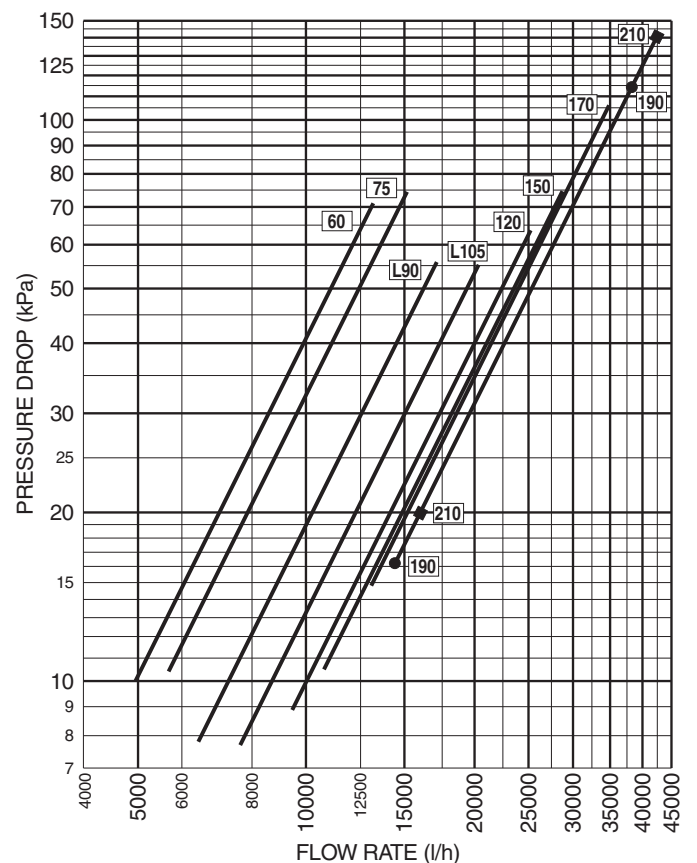

FOULING FACTOR

TABLE 3

COOLER		
Fouling Factor m ² °C/kW	Capacity Factor	Comp. Input Factor
0.044	1.000	1.000
0.088	0.987	0.995
0.176	0.964	0.985
0.352	0.926	0.962

ALTITUDE FACTORS

TABLE 4

Altitude (m)	Capacity Factor	Comp. Input Factor
0	1.000	1.000
600	0.987	1.010
1200	0.973	1.020
1800	0.958	1.029
2400	0.943	1.038

TABLE 5

YCAA-B COOLING CAPACITIES (Standard Units)

Model	LCLT °C	Condenser Entering Air Temperature °C											
		25		30		32		35		40		43	
		Cool kW	Power kW	Cool kW	Power kW	Cool kW	Power kW	Cool kW	Power kW	Cool kW	Power kW	Cool kW	Power kW
YCAA-B 60	6	53.4	18.3	48.9	18.8	47.1	19.0	44.4	19.2	39.8	19.5	37.1	19.8
	7	55.3	18.7	50.9	19.2	49.0	19.4	46.2	19.6	41.5	19.9	38.9	20.2
	8	57.3	19.0	52.7	19.6	50.9	19.7	48.1	19.9	43.3	20.2	40.6	20.5
	10	61.1	19.6	56.4	20.2	54.5	20.4	51.6	20.6	46.8	20.9	44.0	23.1
	12	64.7	20.1	59.9	20.8	57.9	21.3	55.0	21.3	50.0	21.5	47.1	21.9
	15	70.5	21.2	65.4	21.9	63.4	22.3	60.4	22.4	55.2	22.6		
YCAA-B 75	6	61.2	21.4	56.1	22.0	54.0	22.2	50.9	22.4	45.6	22.8	42.5	23.1
	7	63.4	21.8	58.3	22.4	56.2	22.6	53.0	22.9	47.6	23.2	44.6	23.5
	8	65.7	22.2	60.4	22.8	58.3	23.0	55.1	23.3	49.6	23.6	46.5	23.9
	10	70.1	22.9	64.7	23.6	62.5	23.8	59.2	24.1	53.6	24.4	50.4	26.9
	12	74.2	23.5	68.7	24.3	66.4	24.8	63.1	24.8	57.3	24.9		
	15	80.8	24.7	75.0	25.6	72.7	26.0	69.2	26.1				
YCAA-B L90	6	66.8	21.4	64.1	23.3	62.9	24.1	61.1	25.3	54.6	27.4	50.8	28.8
	7	68.8	21.7	66.0	23.5	64.7	24.3	62.9	25.6	56.2	27.7	52.3	29.0
	8	70.7	22.0	67.9	23.9	66.6	24.7	64.7	25.9	57.8	28.0	53.9	29.4
	10	74.7	22.7	71.8	24.6	70.4	25.4	68.4	26.6	61.2	28.8		
	12	78.8	23.3	75.6	25.3	74.2	26.1	72.2	27.4	64.5	29.5		
	15	85.1	24.4	81.6	26.4	80.1	27.2	77.9	28.5				
YCAA-B L105	6	75.7	24.9	73.3	27.2	72.2	28.2	70.5	29.7	64.8	32.3	61.3	34.0
	7	77.9	25.2	75.3	27.5	74.2	28.5	72.6	30.0	66.6	32.6	63.0	34.4
	8	79.9	25.8	77.3	28.1	76.1	29.1	74.4	30.6	68.3	33.3	64.6	35.1
	10	83.7	26.9	81.1	29.3	79.9	30.4	78.0	31.9	71.6	34.7		
	12	87.6	28.1	84.9	30.6	83.6	31.7	81.6	33.3	75.0	36.1		
	15	93.4	30.0	90.5	32.6	89.1	33.7	87.1	35.4				
YCAA-B 120	6	101.9	35.3	93.3	36.2	89.9	36.6	84.6	37.0	75.8	37.6	70.7	38.2
	7	105.5	36.0	97.0	37.0	93.4	37.3	88.2	37.7	79.2	38.2	74.2	38.8
	8	109.3	36.6	100.5	37.7	97.0	38.0	91.6	38.4	82.6	38.9	77.4	39.4
	10	116.6	37.8	107.6	39.0	103.9	39.3	98.4	39.7	89.2	40.2		
	12	123.4	38.8	114.2	40.1	110.5	41.0	104.9	41.0				
	15	134.4	40.8	124.8	42.2	121.0	43.0	115.1	43.1				
YCAA-B 150	6	116.1	43.3	106.3	44.5	102.4	44.9	96.5	45.5	86.4	46.2	80.5	46.9
	7	120.3	44.2	110.5	45.4	106.5	45.8	100.5	46.3	90.2	47.0	84.5	47.7
	8	124.6	45.0	114.6	46.3	110.5	46.7	104.4	47.2	94.1	47.8	88.2	48.4
	10	132.8	46.5	122.6	47.9	118.4	48.3	112.2	48.8	101.6	49.4		
	12	140.6	47.6	130.2	49.2	125.9	50.3	119.5	50.3				
	15	153.1	50.1	142.2	51.8	137.8	52.8	131.2	52.9				
YCAA B 170	6	133.1	41.3	126.0	45.1	123.0	46.7	118.4	49.2	108.5	54.1	102.6	57.1
	7	137.2	41.7	129.9	45.5	126.8	47.2	122.2	49.7	112.0	54.5	105.9	57.5
	8	140.1	42.5	132.9	46.6	129.5	48.0	124.7	50.6	114.4	55.6	108.0	58.6
	10	145.7	44.3	137.9	48.3	134.7	49.9	129.8	52.6	119.0	57.6	112.5	60.7
	12	151.1	46.0	143.1	50.1	139.7	51.8	134.7	54.6	123.5	59.8	116.7	62.9
	15	158.8	48.8	150.4	53.1	147.0	54.9	141.7	57.8	130.2	63.2	123.2	66.4
YCAA B 190	6	146.6	48.1	139.0	52.3	135.9	54.1	131.2	56.8	120.3	61.5	113.7	64.6
	7	151.0	48.7	143.4	52.9	140.1	54.7	135.3	57.3	124.0	62.2	117.2	65.2
	8	155.1	49.8	147.2	54.0	143.9	55.9	139.0	58.6	127.4	63.4	120.4	66.5
	10	163.3	52.0	155.1	56.4	151.6	58.2	146.4	61.0	134.2	65.9	126.9	69.1
	12	171.7	54.3	162.9	58.8	159.3	60.7	153.8	63.6	141.1	68.6		
	15	184.2	58.1	174.9	62.7	171.0	64.6	165.2	67.6	151.5	72.7		
YCAA B 210	6	162.0	49.9	153.3	54.3	149.7	56.2	144.2	59.1	132.2	64.7	125.1	68.1
	7	167.1	50.6	158.0	55.0	154.3	56.8	148.6	59.8	136.3	65.3	128.9	68.7
	8	170.2	51.7	161.1	56.1	157.4	58.1	151.6	61.1	139.1	66.7	131.5	70.1
	10	176.7	54.0	167.2	58.6	163.5	60.5	157.5	63.5	144.4	69.4	136.6	72.9
	12	183.0	56.3	173.2	61.0	169.1	63.0	163.1	66.2	149.7	72.1		
	15	191.9	60.1	181.8	64.9	177.5	67.0	171.2	70.3	157.1	76.6		

 Data not achievable when the 25 bar TÜV high pressure switch is installed

 Data out of the operating limits

LCLT: Leaving chilled liquid temperature **Cool kW:** Cooling capacity

Power kW: Unit power input, including the power input of the compressors, fans, control circuit and power input of the liquid pump to overcome unit pressure drop.

YCAA-B LN COOLING CAPACITIES (Low Noise Units)

TABLE 6

Model	LCLT °C	Condenser Entering Air Temperature °C											
		25		30		32		35		40		43	
		Cool kW	Power kW	Cool kW	Power kW	Cool kW	Power kW	Cool kW	Power kW	Cool kW	Power kW	Cool kW	Power kW
YCAA-B 60 LN	6	55.3	18.5	50.7	19.0	48.8	19.2	46.0	19.4	41.2	19.7	38.4	20.0
	7	57.3	18.8	52.7	19.4	50.8	19.5	47.9	19.8	43.0	20.0	40.3	20.3
	8	59.4	19.2	54.6	19.7	52.7	19.9	49.8	20.1	44.9	20.4	42.0	20.6
	10	63.3	19.8	58.5	20.4	56.5	20.6	53.5	20.8	48.5	21.0	45.6	23.3
	12	67.1	20.3	62.1	21.0	60.0	21.5	57.0	21.5	51.8	21.7		
YCAA-B 75 LN	6	61.8	21.6	56.6	22.2	54.5	22.4	51.3	22.7	46.0	23.1	42.8	23.4
	7	64.0	22.1	58.8	22.7	56.7	22.9	53.4	23.1	48.0	23.5	45.0	23.8
	8	66.3	22.5	60.9	23.1	58.8	23.3	55.6	23.6	50.1	23.8	46.9	24.2
	10	70.7	23.2	65.2	23.9	63.0	24.1	59.7	24.4	54.1	24.7		
	12	74.8	23.8	69.3	24.6	67.0	25.1	63.6	25.1				
YCAA-B L90 LN	6	68.5	22.0	65.7	23.9	64.5	24.7	62.7	25.9	56.0	28.1	52.1	29.5
	7	70.4	22.2	67.5	24.1	66.2	24.9	64.3	26.2	57.5	28.3	53.6	29.7
	8	72.5	22.6	69.6	24.5	68.3	25.3	66.3	26.6	59.3	28.8	55.2	30.2
	10	76.7	23.2	73.6	25.2	72.2	26.0	70.1	27.3	62.8	29.5		
	12	80.8	23.9	77.5	25.9	76.1	26.8	73.9	28.1	66.1	30.3		
YCAA-B L105 LN	6	73.2	26.6	70.9	29.1	69.8	30.2	68.2	31.8	62.6	34.6	59.2	36.4
	7	75.3	27.0	72.7	29.4	71.7	30.5	70.1	32.1	64.3	35.0		
	8	77.0	27.6	74.6	30.1	73.4	31.2	71.7	32.8	65.8	35.8		
	10	80.5	28.9	78.0	31.5	76.8	32.7	75.0	34.3				
	12	84.0	30.3	81.4	33.0	80.2	34.1	78.3	35.9				
YCAA-B 120 LN	6	103.7	35.1	95.0	36.0	91.5	36.4	86.2	36.8	77.2	37.4	72.0	38.0
	7	107.5	35.8	98.7	36.8	95.2	37.1	89.8	37.5	80.6	38.0	75.5	38.6
	8	111.3	36.4	102.4	37.5	98.8	37.8	93.3	38.2	84.1	38.7	78.8	39.2
	10	118.7	37.6	109.5	38.8	105.8	39.1	100.2	39.5	90.8	40.0		
	12	125.7	38.6	116.3	39.9	112.5	40.7	106.8	40.7	97.1	41.3		
YCAA-B 150 LN	6	118.2	42.6	108.3	43.8	104.3	44.2	98.2	44.7	88.0	45.4	82.0	46.1
	7	122.5	43.5	112.5	44.7	108.4	45.1	102.3	45.6	91.9	46.2	86.1	46.9
	8	126.8	44.3	116.6	45.5	112.5	45.9	106.3	46.4	95.8	47.0	89.8	47.6
	10	135.2	45.7	124.8	47.1	120.6	47.5	114.2	48.0	103.5	48.6		
	12	143.2	46.9	132.5	48.4	128.2	49.5	121.7	49.5	110.7	50.2		
YCAA B 170 LN	6	129.6	43.4	122.6	47.4	119.7	49.2	115.2	51.9	105.6	56.6	99.9	59.8
	7	133.6	43.8	126.4	48.0	123.4	49.7	118.9	52.3	109.0	57.2	103.0	60.2
	8	136.4	44.4	129.1	48.4	126.0	50.1	121.4	52.8	111.3	57.6	105.2	60.8
	10	141.7	45.2	134.2	49.3	131.1	51.1	126.3	53.9	115.8	58.6	109.5	61.8
	12	147.0	46.1	139.2	50.3	136.0	52.1	131.1	54.8	120.2	59.7	113.7	62.9
YCAA B 190 LN	6	146.8	47.7	139.3	51.9	136.2	53.7	131.5	56.4	120.5	61.1	113.9	64.2
	7	151.3	48.4	143.6	52.5	140.4	54.3	135.6	57.0	124.3	61.7	117.4	64.8
	8	155.4	49.4	147.5	53.7	144.1	55.5	139.2	58.2	127.6	63.0	120.6	66.1
	10	163.5	51.7	155.3	56.0	151.8	57.9	146.5	60.7	134.4	65.5	127.1	68.7
	12	171.8	54.0	163.1	58.5	159.4	60.4	154.0	63.2	141.2	68.2		
YCAA B 210 LN	6	156.4	51.9	148.1	56.6	144.5	58.5	139.2	61.6	127.7	67.4	120.8	71.0
	7	161.2	52.6	152.5	57.3	148.9	59.2	143.5	62.3	131.7	68.2	124.5	71.7
	8	164.4	53.7	155.6	58.5	152.0	60.5	146.4	63.6	134.3	69.5	127.0	73.1
	10	170.6	56.1	161.4	60.9	157.8	62.9	152.1	66.2	139.4	72.3	131.9	76.0
	12	176.7	58.5	167.3	63.6	163.3	65.6	157.5	68.8	144.5	75.1		
15	185.3	62.4	175.5	67.4	171.4	69.7	165.3	73.1	151.7	79.8			

 Data not achievable when the 25 bar TÜV high pressure switch is installed

 Data out of the operating limits

LCLT: Leaving chilled liquid temperature **Cool kW:** Cooling capacity
Power kW: Unit power input, including the power input of the compressors, fans, control circuit and power input of the liquid pump to overcome unit pressure drop.

TABLE 7 YCAA-B HT COOLING CAPACITIES (High Temperature Units)

Model	LCLT °C	Condenser Entering Air Temperature °C											
		25		30		32		35		40		45	
		Cool kW	Power kW	Cool kW	Power kW	Cool kW	Power kW	Cool kW	Power kW	Cool kW	Power kW	Cool kW	Power kW
YCAA-B 60 HT	6	54.1	18.1	50.5	18.6	49.1	18.8	47.2	19.0	42.7	19.3	37.8	20.1
	7	56.8	18.5	53.1	19.0	51.6	19.2	49.6	19.4	44.6	19.7	39.8	20.1
	8	59.6	18.8	55.7	19.4	54.1	19.6	51.6	19.8	46.5	20.0	41.6	20.4
	10	65.1	19.5	60.6	20.0	58.5	20.2	55.4	20.4	50.2	20.7	45.2	21.2
	12	69.5	20.0	64.3	20.6	62.2	21.1	59.1	21.1	53.7	21.4	48.5	21.9
	15	75.7	21.0	70.3	21.7	68.1	22.1	64.8	22.2	59.3	22.4		
YCAA-B 75 HT	6	62.2	20.8	58.2	21.4	56.5	21.5	54.3	21.8	49.1	22.1	43.5	23.1
	7	65.4	21.2	61.1	21.8	59.4	22.0	57.1	22.2	51.3	22.5	45.8	23.1
	8	68.6	21.6	64.1	22.2	62.3	22.4	59.4	22.6	53.5	22.9	47.8	23.4
	10	74.9	22.3	69.7	23.0	67.3	23.2	63.8	23.4	57.8	23.7	52.0	24.3
	12	80.0	22.8	74.0	23.6	71.6	24.1	68.0	24.1	61.8	24.5		
	15	87.1	24.0	80.9	24.9	78.4	25.3	74.6	25.4				
YCAA-B L90 HT	6	71.9	20.7	68.9	22.5	67.7	23.2	65.8	24.4	58.7	26.4	52.0	28.6
	7	74.1	20.9	71.1	22.6	69.8	23.4	67.8	24.6	60.6	26.6	53.6	28.8
	8	76.3	21.2	73.3	23.0	71.9	23.7	69.9	24.9	62.4	26.9	55.3	29.1
	10	81.0	21.7	77.8	23.5	76.3	24.3	74.1	25.4	66.3	27.5	58.7	29.7
	12	85.7	22.3	82.2	24.1	80.7	24.9	78.5	26.1	70.2	28.1	62.2	30.3
	15	93.0	23.2	89.3	25.0	87.6	25.8	85.2	27.0	76.2	29.0	67.4	31.3
YCAA-B L105 HT	6	81.0	23.6	78.5	25.8	77.3	26.7	75.5	28.1	69.3	30.5	63.0	33.1
	7	83.3	23.7	80.5	25.8	79.4	26.7	77.6	28.1	71.2	30.6	64.9	33.1
	8	85.7	24.2	83.0	26.4	81.7	27.3	79.8	28.7	73.2	31.2	66.7	33.8
	10	90.1	25.2	87.3	27.4	86.0	28.4	84.0	29.8	77.1	32.4	70.2	34.9
	12	94.7	26.2	91.7	28.5	90.3	29.5	88.2	31.0	81.1	33.6	73.8	36.2
	15	101.4	27.8	98.2	30.2	96.7	31.2	94.5	32.8	86.8	35.4		
YCAA-B 120 HT	6	104.2	35.5	97.4	36.5	94.6	36.8	91.0	37.3	82.3	37.9	72.9	39.4
	7	109.5	36.2	102.3	37.2	99.5	37.6	95.6	38.0	85.9	38.5	76.7	39.4
	8	114.8	36.9	107.3	37.9	104.3	38.3	99.4	38.7	89.6	39.1	80.1	40.0
	10	125.4	38.1	116.7	39.2	112.7	39.6	106.8	40.0	96.7	40.5	87.0	41.5
	12	133.9	39.1	123.9	40.4	119.9	41.3	113.8	41.3	103.5	41.8	93.4	42.9
	15	145.8	41.1	135.4	42.5	131.2	43.3	124.9	43.4	114.2	43.8		
YCAA-B 150 HT	6	118.7	44.0	110.9	44.0	107.8	45.6	103.7	46.2	93.7	46.9	83.0	48.8
	7	124.8	44.9	116.6	44.9	113.3	46.5	109.0	47.0	97.9	47.7	87.4	48.8
	8	130.8	45.7	122.2	45.7	118.8	47.4	113.3	47.9	102.1	48.5	91.3	49.5
	10	142.9	47.2	133.0	47.2	128.5	49.0	121.7	49.6	110.2	50.1	99.1	51.5
	12	152.5	48.4	141.2	48.4	136.6	51.1	129.6	51.1	117.9	51.8		
	15	166.1	50.9	154.3	50.9	149.5	53.6	142.3	53.8				
YCAA B 170 HT	6	135.2	41.1	127.9	44.8	124.9	46.4	120.2	49.0	110.2	53.8	104.2	56.7
	7	139.3	41.5	131.5	45.3	128.7	46.9	124.0	49.4	113.7	54.3	107.5	57.2
	8	142.3	42.4	134.6	46.2	131.4	47.8	126.6	50.4	116.1	55.2	109.7	58.3
	10	147.9	44.0	140.0	48.0	136.8	49.7	131.7	52.4	120.8	57.4	114.2	60.4
	12	153.3	45.9	145.2	49.9	141.8	51.6	136.7	54.3	125.4	59.4	118.6	62.6
	15	161.2	48.6	152.7	52.9	149.2	54.6	143.8	57.5	132.2	62.9	125.1	66.0
YCAA B 190 HT	6	154.5	44.8	146.5	48.7	143.2	50.4	138.3	52.8	126.8	57.2	115.2	61.4
	7	159.4	45.4	151.4	49.2	148.0	50.8	142.9	53.3	130.9	57.7	119.0	61.8
	8	164.0	46.3	155.7	50.2	152.2	51.9	146.9	54.4	134.7	58.7	122.4	62.9
	10	173.2	48.3	164.5	52.2	160.8	53.9	155.2	56.5	142.4	60.9	129.4	65.0
	12	182.6	50.3	173.3	54.4	169.4	56.1	163.6	58.7	150.1	63.2	136.5	67.2
	15	196.7	53.6	186.8	57.8	182.7	59.5	176.5	62.1	161.9	66.7	147.2	70.6
YCAA B 210 HT	6	165.3	48.5	156.5	52.8	152.7	54.6	147.2	57.4	135.0	62.7	127.7	66.1
	7	170.4	49.2	161.2	53.5	157.5	55.2	151.7	58.1	139.2	63.4	131.6	66.7
	8	173.8	50.3	164.5	54.6	160.6	56.4	154.7	59.4	142.0	64.7	134.2	68.0
	10	180.3	52.5	170.6	56.9	166.8	58.8	160.8	61.7	147.4	67.4	139.5	70.7
	12	186.8	54.7	176.8	59.4	172.6	61.2	166.5	64.3	152.7	70.0	144.5	73.5
	15	195.9	58.5	185.6	63.1	181.2	65.1	174.7	68.3	160.4	74.4	151.9	77.9

 Data not achievable when the 25 bar TÜV high pressure switch is installed

 Data out of the operating limits

LCLT: Leaving chilled liquid temperature **Cool kW:** Cooling capacity

Power kW: Unit power input, including the power input of the compressors, fans, control circuit and power input of the liquid pump to overcome unit pressure drop.

GLYCOL SELECTION GUIDE

DATA REQUIRED

To select a YORK YCAA-B glycol chiller, the following information is required.

1. Required cooling capacity.
2. Design chilled liquid entering and leaving temperatures.
3. Design chilled liquid flow rate.
4. Design condenser entering air temperature. This will normally be the design summer ambient air temperature unless location or other factors have an influence.
5. Altitude above sea level.
6. Design cooler fouling factor.
7. Static pressure resistance against condenser entering and leaving airflow where ducts, louvres, attenuators, etc., are used, at full unit air flow.

Note: Items 1, 2 and 3 must be linked by the following formulae:

$$\text{Cooling capacity (kW)} = \frac{\text{Range } (^{\circ}\text{C}) \times \text{Flow (l/s)}}{\text{Glycol Factor}}$$

Where:

Range = Entering chilled liquid temperature - leaving chilled liquid temperature.

To determine Glycol Factor refer to Figure 3 for ethylene glycol or Figure 5 for propylene glycol. For the design leaving temperature look up the recommended concentration of glycol and the Glycol Factor at this concentration. This is the minimum concentration which should be used for the design leaving temperature. If a higher concentration is desired the Glycol Factor can be determined from Figure 4 for the ethylene glycol or Figure 6 for propylene glycol.

SELECTION METHOD

1. Determine the correct model of chiller by selecting the model which most closely matches the required capacity at the design conditions of leaving chilled liquid temperature and entering air temperature.
2. Apply the relevant correction factors for fouling factor and altitude (Tables 3 and 4) and glycol concentration (Figures 3 or 5), to the capacity and power values from the capacity tables. Ensure the corrected capacity is still sufficient for requirements.
3. Using the corrected capacity of the selected chiller, adjust the design temperature range, or flow rate, to balance the formulae shown in "Data Required".
4. Physical and electrical data can now be determined from Tables 12 and 13.
5. Always re-check that selections fall within the design limitations specified (Table 2).

SAMPLE SELECTION

A chiller is required for cooling propylene glycol from 4°C to -1°C having a required duty of 48 kW.

The following design conditions apply:

Fouling Factor:	0.088m °C/kW
Altitude:	1200m
Ambient air:	30°C
Glycol Strength:	27% w/w

For propylene glycol leaving at -1°C the recommended concentration from Figure 5 is 27%. The specified strength is therefore suitable.

From ratings using an "Ethylene Glycol" temperature of "-2°C" leaving temperature (Propylene Glycol capacity = Ethylene Glycol capacity at 1°C lower temperature) at 30°C air a YCAA-B L105 gives 49,6 kW capacity and 20,4 kW power (table 9).

From the design fouling factor, corrections of Capacity x 0.987 and power x 0.995 apply (Table 3).

From the design altitude, corrections of Capacity x 0.973 and power x 1.020 apply (Table 4).

From the design glycol strength, corrections of Capacity x 1.040 and power x 1.010 apply, (Interpolation from Table 9).

Applying these factors to the selection: YCAA-B L105

$$\text{Capacity} = 49.6 \times 0.987 \times 0.973 \times 1.040 = 49.5 \text{ kW}$$

$$\text{Compressor Power} = 20.4 \times 0.995 \times 1.020 \times 1.010 = 20.9 \text{ kW}$$

For the glycol concentration specified and a leaving chilled liquid temperature of -1°C, Figure 6 shows a Glycol Factor of 0.243. The flow rate can be determined, therefore, from the formula shown in "Data Required".

$$49.6 \text{ kW} = \frac{(4 - (-1)) \times \text{Flow (l/s)}}{0.243}$$

$$\text{Flow rate} = \frac{49.6 \times 0.243}{5} = 2.4 \text{ (l/s) or } 8640 \text{ (l/h)}$$

This satisfies the Operating Limits.

Cooler pressure drop can be found by taking the value of water pressure drop Figure 2, for a YCAA-B L105 and multiplying by the correction factor (Figure 8), for 27% strength and a mean temperature of 1.5°C,

$$\text{i.e. } (4 + (-1))/2^{\circ}\text{C:}$$

$$10.5 \text{ kPa} \times 1.25 = 13.1 \text{ kPa}$$

FIGURE 3 RECOMMENDED CONCENTRATIONS FOR ETHYLENE GLYCOL SOLUTIONS

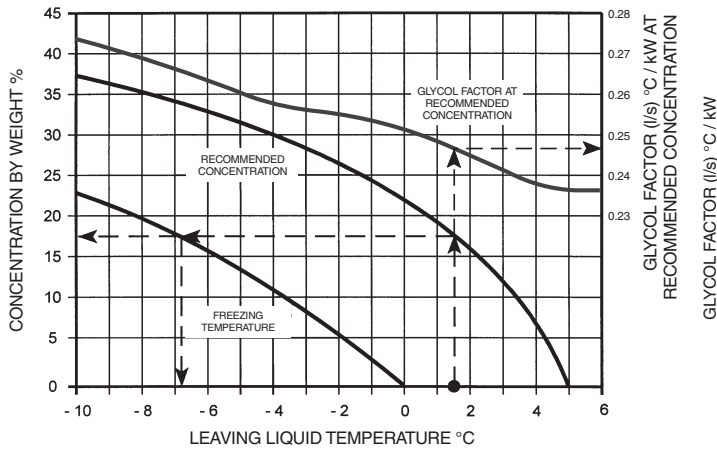

FIGURE 4 FACTORS AT OTHER CONCENTRATIONS FOR ETHYLENE GLYCOL SOLUTIONS

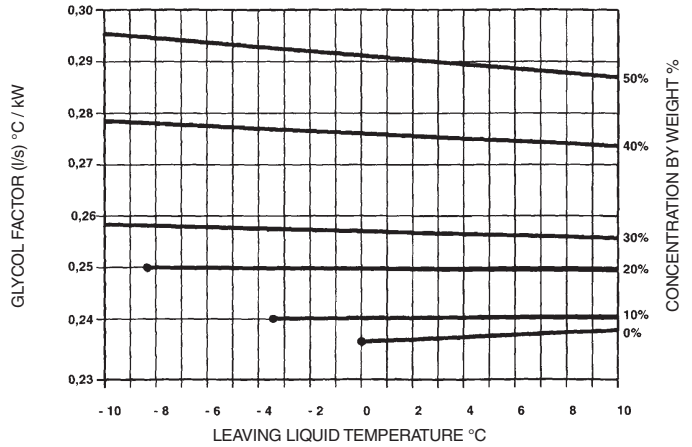

FIGURE 5 RECOMMENDED CONCENTRATIONS FOR PROPYLENE GLYCOL SOLUTIONS

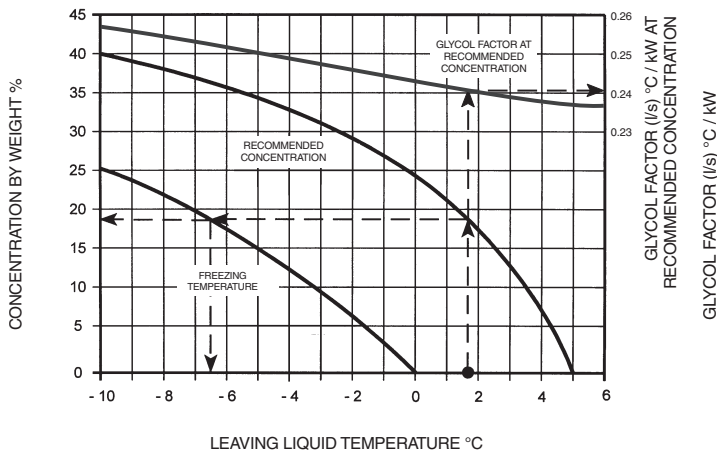

FIGURE 6 FACTORS AT OTHER CONCENTRATIONS FOR PROPYLENE GLYCOL SOLUTIONS

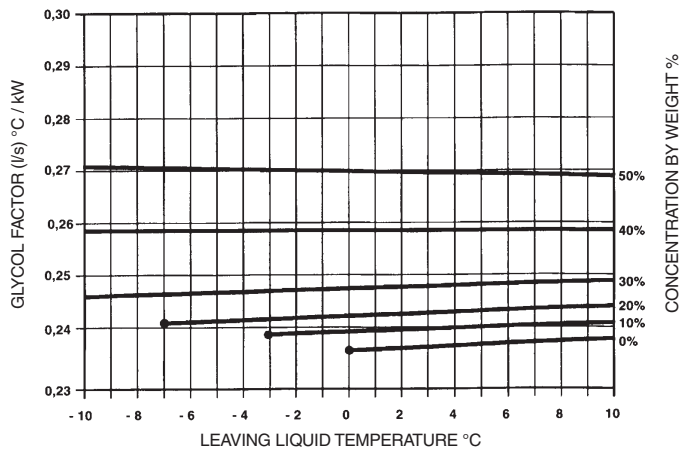

FIGURE 7 PRESSURE DROP CORRECTION FACTORS FOR ETHYLENE GLYCOL SOLUTIONS

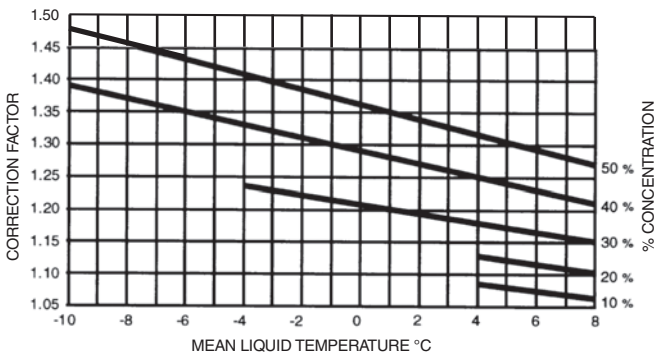
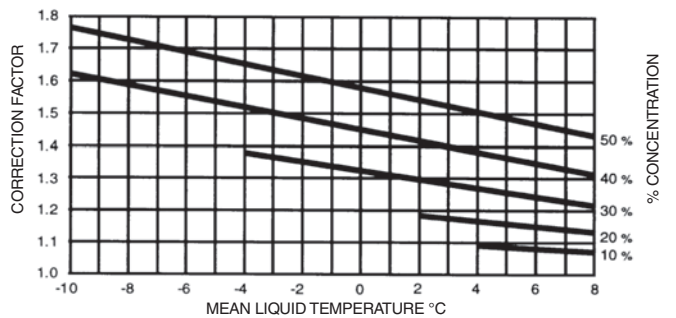

FIGURE 8 PRESSURE DROP CORRECTION FACTORS FOR PROPYLENE GLYCOL SOLUTIONS



YCAA-B COOLING CAPACITIES (35% ETHYLENE GLYCOL)

TABLE 8

Model	LCLT °C	Condenser Entering Air Temperature °C											
		25		30		32		35		40		43	
		Cool kW	Power kW	Cool kW	Power kW	Cool kW	Power kW	Cool kW	Power kW	Cool kW	Power kW	Cool kW	Power kW
YCAA B 60	-8	27.3	13.2	25.1	13.5	24.2	13.6	22.8	13.8	20.5	14.0	19.2	14.2
	-6	30.2	13.8	27.7	14.2	26.7	14.3	25.2	14.5	22.7	14.7	21.2	14.9
	-4	33.3	14.5	30.6	14.9	29.4	15.0	27.8	15.2	25.0	15.4	23.4	15.6
	-2	36.5	15.1	33.5	15.6	32.3	15.7	30.5	15.9	27.4	16.1	25.6	16.3
	0	39.9	15.8	36.7	16.3	35.3	16.4	33.3	16.6	29.9	16.8	28.0	17.1
YCAA B 75	-8	31.3	15.4	28.8	15.8	27.7	15.9	26.2	16.1	23.5	16.3	22.0	16.6
	-6	34.6	16.1	31.8	16.6	30.6	16.7	28.9	16.9	26.0	17.1	24.3	17.4
	-4	38.1	16.9	35.0	17.4	33.8	17.5	31.8	17.7	28.6	18.0	26.8	18.2
	-2	41.8	17.7	38.4	18.2	37.0	18.3	34.9	18.5	31.4	18.8	29.4	19.1
	0	45.7	18.5	42.0	19.0	40.5	19.2	38.2	19.4	34.3	19.7	32.1	20.0
YCAA B L90	-8	33.9	15.3	32.6	16.6	31.9	17.2	31.0	18.0	27.7	19.5	25.8	20.5
	-6	37.5	16.0	36.0	17.4	35.3	18.0	34.3	18.9	30.7	20.5	28.6	21.5
	-4	41.3	16.8	39.6	18.2	38.9	18.9	37.8	19.8	33.8	21.5	31.4	22.5
	-2	45.3	17.6	43.5	19.1	42.7	19.7	41.4	20.7	37.0	22.5	34.5	23.6
	0	49.6	18.4	47.5	20.0	46.7	20.6	45.3	21.7	40.5	23.5	37.7	24.6
YCAA B L105	-8	38.5	17.8	37.2	19.4	36.6	20.1	35.8	21.2	32.9	23.0	31.1	24.2
	-6	42.5	18.6	41.1	20.3	40.5	21.1	39.6	22.2	36.3	24.1	34.4	25.4
	-4	46.8	19.5	45.3	21.3	44.6	22.1	43.6	23.3	40.0	25.3	37.9	26.6
	-2	51.4	20.4	49.6	22.3	48.9	23.1	47.8	24.3	43.9	26.5	41.6	27.9
	0	56.2	21.4	54.3	23.3	53.5	24.2	52.3	25.4	48.0	27.7	45.4	29.1
YCAA B 120	-8	52.1	25.4	47.9	26.1	46.1	26.3	43.5	26.6	39.1	27.0	36.6	27.4
	-6	57.6	26.6	52.9	27.3	51.0	27.6	48.1	27.9	43.2	28.3	40.5	28.7
	-4	63.4	27.9	58.3	28.6	56.1	28.9	53.0	29.2	47.6	29.6	44.6	30.1
	-2	69.6	29.2	63.9	30.0	61.6	30.3	58.1	30.6	52.2	31.0	48.9	31.5
	0	76.1	30.5	69.9	31.3	67.4	31.6	63.5	32.0	57.1	32.4	53.5	32.9
YCAA B 150	-8	59.4	31.2	54.5	32.0	52.6	32.3	49.6	32.7	44.5	33.1	41.7	33.6
	-6	65.6	32.7	60.3	33.6	58.1	33.9	54.8	34.3	49.2	34.8	46.1	35.3
	-4	72.3	34.3	66.4	35.2	64.0	35.5	60.4	35.9	54.2	36.4	50.8	37.0
	-2	79.3	35.9	72.8	36.8	70.2	37.2	66.2	37.6	59.5	38.1	55.7	38.7
	0	86.7	37.5	79.6	38.5	76.8	38.9	72.4	39.3	65.0	39.8	60.9	40.4
YCAA B 170	-8	67.7	29.4	64.1	32.1	62.6	33.3	60.3	35.0	55.3	38.5	52.3	40.6
	-6	74.9	30.8	70.9	33.7	69.2	34.9	66.7	36.8	61.1	40.3	57.8	42.6
	-4	82.5	32.3	78.0	35.3	76.2	36.6	73.4	38.5	67.3	42.3	63.6	44.6
	-2	90.5	33.8	85.6	36.9	83.6	38.3	80.5	40.3	73.9	44.2	69.8	46.7
	0	98.9	35.3	93.6	38.6	91.4	40.0	88.1	42.1	80.8	46.3	76.3	48.8
YCAA B 190	-8	74.5	34.3	70.8	37.3	69.2	38.6	66.8	40.4	61.2	43.8	57.9	46.0
	-6	82.4	36.0	78.2	39.1	76.5	40.5	73.8	42.4	67.7	46.0	64.0	48.3
	-4	90.7	37.7	86.1	41.0	84.2	42.4	81.3	44.4	74.5	48.2	70.4	50.6
	-2	99.5	39.5	94.5	42.9	92.4	44.4	89.2	46.5	81.8	50.4	77.3	52.9
	0	108.9	41.3	103.3	44.9	101.0	46.4	97.5	48.6	89.4	52.7	84.5	55.3
YCAA B 210	-8	82.5	35.7	78.0	38.8	76.1	40.1	73.4	42.2	67.3	46.1	63.6	48.5
	-6	91.2	37.4	86.2	40.7	84.2	42.1	81.1	44.2	74.4	48.3	70.4	50.8
	-4	100.4	39.2	94.9	42.7	92.7	44.1	89.3	46.4	81.9	50.7	77.5	53.3
	-2	110.1	41.0	104.1	44.6	101.7	46.1	98.0	48.5	89.9	53.0	85.0	55.8
	0	120.4	42.9	113.9	46.7	111.2	48.2	107.1	50.7	98.3	55.4	92.9	58.3
YCAA B 210	-8	142.6	46.7	134.8	50.8	131.7	52.5	126.9	55.3	116.4	60.4	110.1	63.5

LCLT: Leaving chilled liquid temperature

Cool kW: Cooling capacity

Power kW: Unit power input, including the power input of the compressors, fans, control circuit and power input of the liquid pump to overcome unit pressure drop.

COOLING CAPACITY CORRECTION FACTORS FOR OTHER GLYCOL CONCENTRATIONS

TABLE 9

% By Weight	Ethylene Glycol		Propylene Glycol	
	Capacity Factor	Compressor Input Factor	Capacity Factor	Compressor Input Factor
10	1.061	1.025	1.097	1.033
20	1.036	1.015	1.067	1.023
30	1.015	1.005	1.026	1.008
35	1.000	1.000	1.000	1.000
40	0.985	0.995	0.974	0.992
50	0.954	0.985	0.923	0.977

If a selection at different glycol percentage is required, multiply the capacity and input power values table 8 (35% ethylene glycol) by the capacity and input factors for the new glycol percentages.

TABLE 10

YCAA-B LN COOLING CAPACITIES (35% ETHYLENE GLYCOL)

Model	LCLT °C	Codenser entering Air Temperature °C											
		25		30		32		35		40		43	
		Cool kW	Power kW	Cool kW	Power kW	Cool kW	Power kW	Cool kW	Power kW	Cool kW	Power kW	Cool kW	Power kW
YCAA B 60 LN	-8	28.3	13.3	26.0	13.6	25.1	13.8	23.6	13.9	21.2	14.1	19.9	14.3
	-6	31.3	13.9	28.7	14.3	27.7	14.4	26.1	14.6	23.5	14.8	22.0	15.0
	-4	34.5	14.6	31.7	15.0	30.5	15.1	28.8	15.3	25.9	15.5	24.2	15.8
	-2	37.8	15.3	34.7	15.7	33.5	15.8	31.6	16.0	28.4	16.2	26.6	16.5
	0	41.3	16.0	38.0	16.4	36.6	16.6	34.5	16.8	31.0	17.0	29.1	17.2
4	49.0	17.4	45.0	17.9	43.3	18.0	40.9	18.2	36.7	18.5	34.4	18.8	
YCAA B 75 LN	-8	31.6	15.6	29.0	16.0	28.0	16.1	26.4	16.3	23.7	16.5	22.2	16.8
	-6	34.9	16.3	32.1	16.8	30.9	16.9	29.2	17.1	26.2	17.4	24.5	17.6
	-4	38.4	17.1	35.3	17.6	34.0	17.7	32.1	17.9	28.8	18.2	27.0	18.5
	-2	42.2	17.9	38.8	18.4	37.3	18.6	35.2	18.8	31.7	19.0	29.6	19.3
	0	46.1	18.7	42.4	19.2	40.8	19.4	38.5	19.6	34.6	19.9	32.4	20.2
4	54.6	20.4	50.2	20.9	48.4	21.1	45.6	21.4	41.0	21.7	38.4	22.0	
YCAA B L90 LN	-8	34.7	15.6	33.3	17.0	32.7	17.6	31.8	18.4	28.4	20.0	26.4	21.0
	-6	38.4	16.4	36.8	17.8	36.1	18.4	35.1	19.4	31.4	21.0	29.2	22.0
	-4	42.3	17.2	40.6	18.7	39.8	19.3	38.7	20.3	34.6	22.0	32.2	23.0
	-2	46.4	18.0	44.5	19.5	43.7	20.2	42.4	21.2	37.9	23.0	35.3	24.1
	0	50.7	18.8	48.7	20.4	47.7	21.1	46.4	22.2	41.5	24.0	38.6	25.2
4	60.1	20.5	57.6	22.3	56.5	23.0	54.9	24.2	49.1	26.2	45.7	27.5	
YCAA B L105 LN	-8	37.1	19.0	35.9	20.8	35.4	21.5	34.6	22.7	31.7	24.7	29.3	26.0
	-6	41.1	20.0	39.7	21.8	39.1	22.6	38.2	23.8	35.1	25.9	32.4	27.3
	-4	45.2	20.9	43.7	22.8	43.1	23.7	42.1	24.9	38.6	27.1	35.7	28.6
	-2	49.6	21.9	47.9	23.9	47.2	24.8	46.2	26.1	42.4	28.4	39.1	29.9
	0	54.2	22.9	52.4	25.0	51.6	25.9	50.5	27.3	46.4	29.7	42.8	31.2
4	64.2	24.9	62.1	27.2	61.2	28.2	59.8	29.7	54.9	32.3	50.7	34.0	
YCAA B 120 LN	-8	53.1	25.2	48.7	25.9	47.0	26.1	44.3	26.5	39.8	26.8	37.3	27.2
	-6	58.6	26.5	53.9	27.2	51.9	27.4	49.0	27.8	44.0	28.1	41.2	28.6
	-4	64.6	27.7	59.3	28.5	57.2	28.7	53.9	29.1	48.5	29.5	45.4	29.9
	-2	70.9	29.0	65.1	29.8	62.7	30.1	59.2	30.4	53.2	30.9	49.8	31.3
	0	77.5	30.3	71.2	31.2	68.6	31.5	64.7	31.8	58.1	32.3	54.4	32.8
4	91.7	33.1	84.3	34.0	81.2	34.3	76.6	34.7	68.8	35.1	64.5	35.7	
YCAA B 150 LN	-8	60.4	30.7	55.5	31.5	53.5	31.8	50.5	32.1	45.4	32.6	42.5	33.1
	-6	66.8	32.2	61.4	33.0	59.2	33.3	55.8	33.7	50.1	34.2	47.0	34.7
	-4	73.6	33.7	67.6	34.6	65.1	34.9	61.4	35.3	55.2	35.8	51.7	36.4
	-2	80.7	35.3	74.2	36.2	71.5	36.6	67.4	37.0	60.6	37.5	56.7	38.1
	0	88.3	36.9	81.1	37.9	78.1	38.2	73.7	38.7	66.2	39.2	62.0	39.8
4	104.5	40.2	96.0	41.3	92.5	41.6	87.3	42.1	78.4	42.7	73.5	43.4	
YCAA B 170 LN	-8	65.9	30.2	62.4	33.3	60.9	34.5	58.7	36.5	53.8	40.0	50.9	42.2
	-6	72.9	31.7	69.0	34.9	67.3	36.2	64.9	38.2	59.5	41.9	56.2	44.2
	-4	80.2	33.3	75.9	36.6	74.1	38.0	71.4	40.1	65.5	44.0	61.9	46.4
	-2	88.0	34.8	83.3	38.3	81.3	39.8	78.4	41.9	71.9	46.0	67.9	48.5
	0	96.3	36.4	91.1	40.0	88.9	41.6	85.7	43.8	78.6	48.1	74.3	50.7
4	114.0	39.6	107.9	43.6	105.3	45.3	101.5	47.8	93.1	52.4	88.0	55.3	
YCAA B 190 LN	-8	74.7	34.1	70.9	37.0	69.3	38.3	66.9	40.2	61.3	43.5	58.0	45.7
	-6	82.6	35.8	78.4	38.9	76.6	40.2	74.0	42.2	67.8	45.7	64.1	47.9
	-4	90.9	37.5	86.3	40.7	84.4	42.1	81.4	44.2	74.7	47.8	70.6	50.2
	-2	99.7	39.2	94.7	42.6	92.6	44.1	89.4	46.2	81.9	50.1	77.4	52.6
	0	109.1	41.0	103.5	44.5	101.2	46.1	97.7	48.3	89.6	52.4	84.7	54.9
4	129.2	44.7	122.6	48.5	119.9	50.2	115.7	52.7	106.1	57.0	100.3	59.9	
YCAA B 210 LN	-8	79.6	36.1	75.3	39.6	73.5	41.0	70.8	43.2	65.0	47.5	61.5	50.1
	-6	88.0	37.9	83.2	41.5	81.3	43.0	78.3	45.3	71.8	49.9	67.9	52.5
	-4	96.9	39.7	91.6	43.5	89.5	45.0	86.2	47.5	79.1	52.2	74.8	55.0
	-2	106.3	41.5	100.5	45.5	98.2	47.1	94.6	49.7	86.8	54.7	82.1	57.6
	0	116.2	43.4	109.9	47.6	107.4	49.3	103.4	52.0	94.9	57.2	89.7	60.2
4	137.6	47.3	130.2	51.8	127.1	53.7	122.5	56.6	112.4	62.3	106.3	65.6	

LCLT: Leaving chilled liquid temperature

Cool kW: Cooling capacity

Power kW: Unit power input, including the power input of the compressors, fans and control circuit

SOUND POWER LEVELS (FREQUENCY ANALYSIS (SPECTRUM)) TABLE 11

YCAA-B STD								
Model	FREQUENCY (Hz)							dB(A)
	125	250	500	1000	2000	4000	8000	
60	86	84	83	82	80	70	59	86
75	86	84	83	82	80	70	59	86
L90	87	85	84	83	81	71	60	87
L105	88	86	85	84	82	72	61	88
120	89	87	86	85	83	73	62	89
150	89	87	86	85	83	73	62	89
170	86	90	87	87	85	81	72	92
190	87	91	88	88	86	82	73	93
210	87	91	88	88	86	82	73	93

YCAA-B LN								
Model	FREQUENCY (Hz)							dB(A)
	125	250	500	1000	2000	4000	8000	
60	77	75	74	73	71	61	50	77
75	77	75	74	73	71	61	50	77
L90	77	75	74	73	71	61	50	77
L105	80	78	77	76	74	64	53	80
120	78	76	75	74	72	62	51	78
150	81	79	78	77	75	65	54	81
170	76	80	77	77	75	71	62	82
190	78	82	79	79	77	73	64	84
210	78	82	79	79	77	73	64	84

YCAA-B HT								
Model	FREQUENCY (Hz)							dB(A)
	125	250	500	1000	2000	4000	8000	
60	87	85	84	83	81	71	60	87
75	87	85	84	83	81	71	60	87
L90	90	88	87	86	84	74	63	90
L105	90	88	87	86	84	74	63	90
120	92	90	89	88	86	76	65	92
150	92	90	89	88	86	76	65	92
170	87	91	88	88	86	82	73	93
190	88	92	89	89	87	83	74	94
210	88	92	89	89	87	83	74	94

TABLE 12

PHYSICAL DATA (Standard Units)

YCAA-B			60	75	L90	L105
Number of refrigerant circuits			2	2	2	2
Total capacity steps			2	2	2	2
Compressor	Number		2	2	2	2
	Theoretical displacement	m ³ /h	36.16	43.16	37.7	43.5
	No. of cylinders		3	3	SCROLL	SCROLL
	Nominal speed	rpm	2950	2950	2950	2950
	Oil charge (per compressor)	l	2.8	2.8	4	6.6
	Oil type		22APOE		160SZ POE	
Evaporator	No. of loading stages	%	50-100	50-100	50-100	50-100
	Number		2	2	2	2
	Type		Plate	Plate	Plate	Plate
	Water volume per evaporator	l	2.8	3.3	3.8	4.7
Air cooled	Total coil face area	m ²	4.2	4.2	4.2	4.2
	Number of coils		2	2	2	2
Condenser	Number of rows		2	2	3	3
	Number of fans		2	2	2	2
Fans	Nominal speed	rpm	910	910	910	910
	Total airflow	m ³ /s	5.3	5.3	6.1	6.1
	Total power (standard fans)	kW	0.96	0.96	0.96	0.96
	Total power (high pressure fans)	kW	1.96	1.96	1.96	1.96
	Refrigerant Charge					
Circuit 1		kg	6.0	6.5	8.5	12.0
	Circuit 2	kg	6.0	6.5	8.5	12.0
Weight (total)	Operating	kg	600	624	784	827
	Shipping	kg	579	605	763	805
Sound power level ⁽²⁾		dB(A)	86	86	87	88
Sound pressure level at 10 m ⁽³⁾		dB(A)	55	55	56	57
Dimensions	Length	mm	2110	2110	2110	2110
	Width	mm	1110	1110	1110	1110
	Height	mm	1750	1750	1750	1750

YCAA-B			120	150	170	190	210
Number of refrigerant circuits			2	2	2	2	2
Total capacity steps			2	2	4	4	4
Compressor	Number		2	2	4	4	4
	Theoretical displacement	m ³ /h	76.85	88.94	72.5	81.2	87
	No. of cylinders		6	6	SCROLL	SCROLL	SCROLL
	Nominal speed	rpm	2950	2950	2950	2950	2950
	Oil charge (per compressor)	l	6.6	6.6	10.4	10.6	13.2
	Oil type		22APOE		160SZ POE		
Evaporator	No. of loading stages	%	50-100	50-100	20-50-70-100	25-50-75-100	25-50-75-100
	Number		2	2	1	1	1
	Type		Plate	Plate	Plate	Plate	Plate
	Water volume per evaporator	l	5.6	6.6	12.4	14.6	14.6
Air cooled	Total coil face area	m ²	5.9	5.9	8.4	8.4	8.4
	Number of coils		2	2	4	4	4
Condenser	Number of rows		3	4	3	3	4
	Number of fans		3	3	3	3	3
Fans	Nominal speed	rpm	910	910	910	910	910
	Total airflow	m ³ /s	7.5	7.2	12.3	12.3	11.7
	Total power (standard fans)	kW	1.44	1.44	2.94	2.94	2.94
	Total power (high pressure fans)	kW	2.94	2.94	4.2	4.2	4.2
	Refrigerant Charge						
Circuit 1		kg	10.5	11.5	18.5	19.5	25.0
	Circuit 2	kg	10.5	11.5	18.5	19.5	25.0
Weight (total)	Operating	kg	888	962	1344	1383	1488
	Shipping	kg	859	930	1332	1368	1473
Sound power level ⁽¹⁾		dB(A)	89	89	92	93	93
Sound pressure level at 10 m ⁽²⁾		dB(A)	58	58	61	62	62
Dimensions	Length	mm	2760	2760	3450	3450	3450
	Width	mm	1110	1110	1110	1110	1110
	Height	mm	1750	1750	2120	2120	2120

(1) Sound levels are at fully loaded conditions. Sound power level values refer to ISO standard 3744 and Eurovent 8/1

(2) Sound pressure level values refer to ISO standard 3744

PHYSICAL DATA (Low Noise Units)

TABLE 12

YCAA-B LN			60	75	L90	L105
Number of refrigerant circuits			2	2	2	2
Total capacity steps			2	2	2	2
Compressor	Number		2	2	2	2
	Theoretical displacement	m ³ /h	36.16	43.16	37.7	43.5
	No. of cylinders		3	3	SCROLL	SCROLL
	Nominal speed	rpm	2950	2950	2950	2950
	Oil charge (per compressor)	l	2.8	2.8	4	6.6
	Oil type		22APOE		160SZ POE	
Evaporator	No. of loading stages	%	50-100	50-100	50-100	50-100
	Number		2	2	2	2
	Type		Plate	Plate	Plate	Plate
	Water volume per evaporator	l	2.8	3.3	3.8	4.7
Air cooled	Total coil face area	m ²	4.2	4.2	4.2	4.2
	Number of coils		2	2	2	2
Condenser	Number of rows		2	2	3	3
	Number of fans		2	2	2	2
Fans	Nominal speed	rpm	580	580	580	680
	Total airflow	m ³ /s	4.2	4.2	4.1	4.2
	Total power	kW	1.4	1.4	1.4	1.4
	Refrigerant Charge	Circuit 1	kg	6.0	6.5	8.5
	Circuit 2	kg	6.0	6.5	8.5	12.0
Weight (total)	Operating	kg	642	668	826	837
	Shipping	kg	622	648	805	814
Sound power level ⁽¹⁾		dB(A)	77	77	77	80
Sound pressure level at 10 m ⁽²⁾		dB(A)	46	46	46	49
Dimensions	Length	mm	2110	2110	2110	2110
	Width	mm	1110	1110	1110	1110
	Height	mm	1850	1850	1850	1850

YCAA-B LN			120	150	170	190	210
Number of refrigerant circuits			2	2	2	2	2
Total capacity steps			2	2	4	4	4
Compressor	Number		2	2	4	4	4
	Theoretical displacement	m ³ /h	76.85	88.94	72.5	81.2	87
	No. of cylinders		6	6	SCROLL	SCROLL	SCROLL
	Nominal speed	rpm	2950	2950	2950	2950	2950
	Oil charge (per compressor)	l	6.6	6.6	10.4	10.6	13.2
	Oil type		22APOE		160SZ POE		
Evaporator	No. of loading stages	%	50-100	50-100	20-50-70-100	25-50-70-100	25-50-75-100
	Number		2	2	1	1	1
	Type		Plate	Plate	Plate	Plate	Plate
	Water volume per evaporator	l	5.6	6.6	12.4	12.4	14.6
Air cooled	Total coil face area	m ²	5.9	5.9	8.4	8.4	8.4
	Number of coils		2	2	4	4	4
Condenser	Number of rows		3	4	4	4	4
	Number of fans		3	3	3	3	3
Fans	Nominal speed	rpm	580	680	500	500	700
	Total airflow	m ³ /s	5.6	7.0	7.9	9.6	9.6
	Total power	kW	2.1	2.1	4.2	4.2	4.2
	Refrigerant Charge	Circuit 1	kg	11.0	11.5	21.0	22.0
	Circuit 2	kg	11.0	11.5	21.0	22.0	25.0
Weight (total)	Operating	kg	950	974	1434	1473	1506
	Shipping	kg	920	943	1422	1458	1491
Sound power level ⁽¹⁾		dB(A)	78	81	82	84	84
Sound pressure level at 10 m ⁽²⁾		dB(A)	47	50	51	53	53
Dimensions	Length	mm	2760	2760	3450	3450	3450
	Width	mm	1110	1110	1110	1110	1110
	Height	mm	1850	1850	2150	2150	2150

(1) Sound levels are at fully loaded conditions. Sound power level values refer to ISO standard 3744 and Eurovent 8/1

(2) Sound pressure level values refer to ISO standard 3744

TABLE 12

PHYSICAL DATA (High Temperature Units)

YCAA-B HT			60	75	L90	L105
Number of refrigerant circuits			2	2	2	2
Total capacity steps			2	2	2	2
Compressor	Number		2	2	2	2
	Theoretical displacement	m ³ /h	36.16	43.16	37.7	43.5
	No. of cylinders		3	3	SCROLL	SCROLL
	Nominal speed	rpm	2950	2950	2950	2950
	Oil charge (per compressor)	l	2.8	2.8	4	6.6
	Oil type		22APOE		160SZ POE	
Evaporator	Number		2	2	2	2
	Type		Plate	Plate	Plate	Plate
	Water volume per evaporator	l	2.8	3.3	3.8	4.7
Air cooled	Total coil face area	m ²	4.2	4.2	4.2	4.2
	Number of coils		2	2	2	2
Condenser	Number of rows		2	2	3	3
Fans	Number of fans		2	2	2	2
	Nominal speed	rpm	910	910	910	910
	Total airflow	m ³ /s	5.2	5.2	7.2	6.9
	Total power	kW	0.96	0.96	1.96	1.96
Refrigerant Charge	Circuit 1	kg	6.5	7.5	8.5	12.0
	Circuit 2	kg	6.5	7.5	8.5	12.0
Weight (total)	Operating	kg	634	662	794	837
	Shipping	kg	614	641	772	815
Sound power level ⁽¹⁾		dB(A)	87	87	90	90
Sound pressure level at 10 m ⁽²⁾		dB(A)	56	56	59	59
Dimensions	Length	mm	2110	2110	2110	2110
	Width	mm	1110	1110	1110	1110
	Height	mm	1750	1750	1850	1850

YCAA-B HT			120	150	170	190	210
Number of refrigerant circuits			2	2	2	2	2
Total capacity steps			2	2	4	4	4
Compressor	Number		2	2	4	4	4
	Theoretical displacement	m ³ /h	76.85	88.94	72.5	72.5	87
	No. of cylinders		6	6	SCROLL	SCROLL	SCROLL
	Nominal speed	rpm	2950	2950	2950	2950	2950
	Oil charge (per compressor)	l	6.6	6.6	10.4	10.6	13.2
	Oil type		22APOE		160SZ POE		
Evaporator	Number		2	2	1	1	1
	Type		Plate	Plate	Plate	Plate	Plate
	Water volume per evaporator	l	5.6	6.6	12.4	12.4	14.6
Air cooled	Total coil face area	m ²	5.9	5.9	8.4	8.4	8.4
	Number of coils		2	2	4	4	4
Condenser	Number of rows		3	4	4	3	4
Fans	Number of fans		3	3	3	3	3
	Nominal speed	rpm	910	910	900	900	900
	Total airflow	m ³ /s	10.0	9.4	15.2	15.2	14.4
	Total power	kW	2.94	2.94	4.2	4.2	4.2
Refrigerant Charge	Circuit 1	kg	12.5	14.0	18.5	19.5	25.0
	Circuit 2	kg	12.5	14.0	18.5	19.5	25.0
Weight (total)	Operating	kg	906	978	1368	1407	1506
	Shipping	kg	877	948	1353	1392	1491
Sound power level ⁽¹⁾		dB(A)	92	92	93	94	94
Sound pressure level at 10 m ⁽²⁾		dB(A)	61	61	62	65	63
Dimensions	Length	mm	2760	2760	3450	3450	3450
	Width	mm	1110	1110	1110	1110	1110
	Height	mm	1850	1850	2150	2150	2150

(1) Sound levels are at fully loaded conditions. Sound power level values refer to ISO standard 3744 and Eurovent 8/1

(2) Sound pressure level values refer to ISO standard 3744

YCAA-B STD-LN-HT

YCAA-B		60	75	L90	L105	120	150	170	190	210
Current Input (A)	Nominal ⁽¹⁾	28	33	46	50	57	67	88	100	107
	Maximum ⁽²⁾	35	45	73	73	76	91	127	147	147
Power Input (KW)	Nominal ⁽¹⁾	19.6	22.9	25.4	30	37.7	46.3	49	56.5	59
	Maximum ⁽²⁾	23	29	27.5	33.5	49	59	58	62	68
Max. instantaneous current (A) ⁽³⁾		98	149	213	213	229	262	267	285	287

(1) Nominal conditions taken at 7°C leaving chilled water temperature and 35°C ambient temperature

(2) Maximum conditions for the compressor are taken at 14°C leaving chilled water temperature and 45°C ambient temperature

(3) Maximum instantaneous current is the largest compressor LRA starting current, plus the nominal current of the other compressor and fan

Unit power input includes: the power input of the compressors, fans, control circuit and the power input of the pump against the unit pressure drops

YCAA-B STD 230-3-50

YCAA-B		75	L105	L150
Current Input (A)	Nominal ⁽¹⁾	82	95	173
	Maximum ⁽²⁾	99	139	205
Power Input (KW)	Nominal ⁽¹⁾	22.9	30	46.3
	Maximum ⁽²⁾	29	33	61
Max. instantaneous current (A) ⁽³⁾		303	381	553

(1) Nominal conditions taken at 7°C leaving chilled water temperature and 35°C ambient temperature

(2) Maximum conditions for the compressor are taken at 14°C leaving chilled water temperature and 45°C ambient temperature

(3) Maximum instantaneous current is the largest compressor LRA starting current, plus the nominal current of the other compressor and fan

ELECTRICAL CONNECTIONS (YCAA-B Models 60 -150 Standard Control)

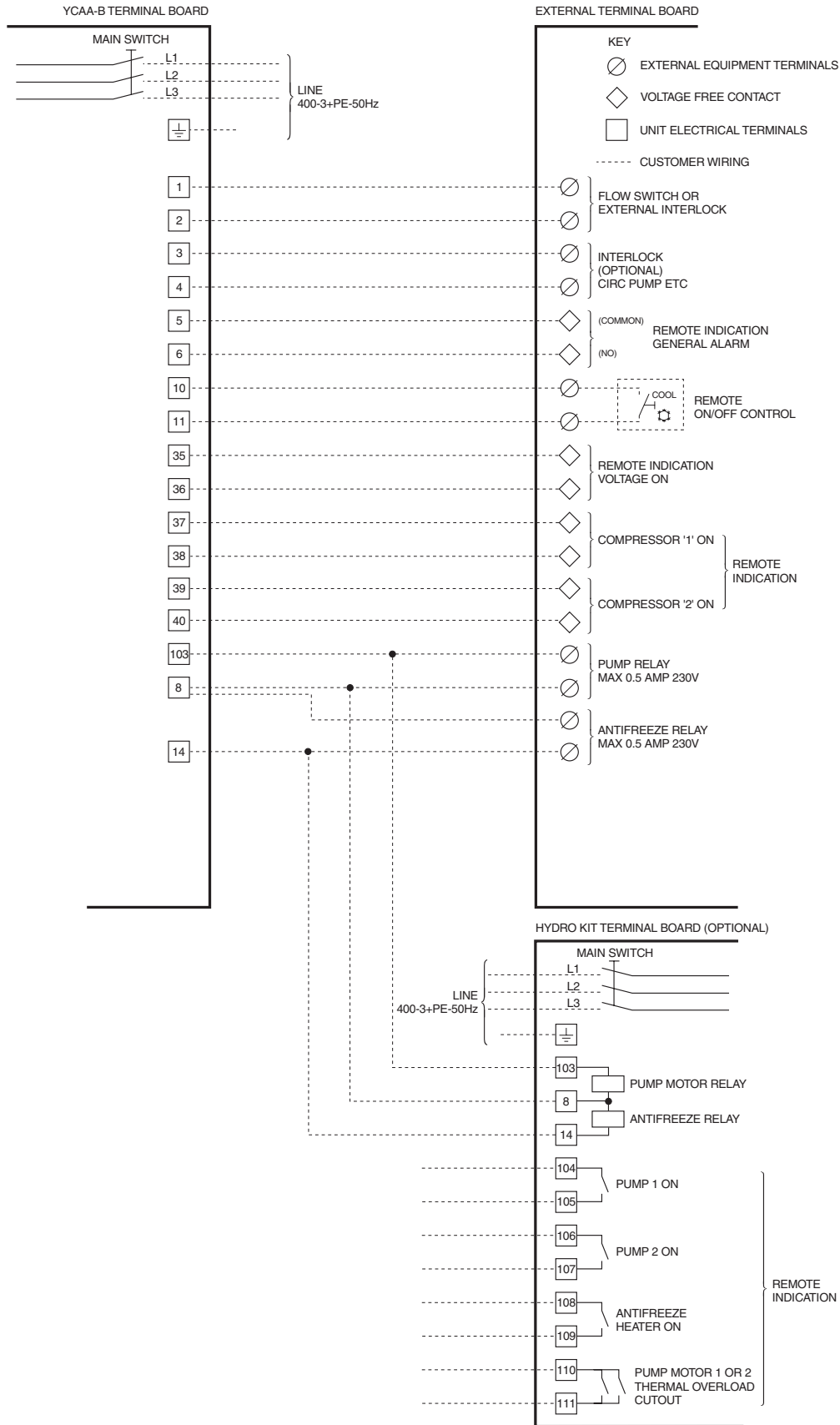

The following connections are required:

- One 400-3-50 Hz supply plus earth.
- Control interlocks if required.

The power connections and interlocks can be made to a single terminal strip. Supply cables should enter the unit via a hole provided.

Mains isolator switches should be located adjacent to the unit and should incorporate provision for locking in the off position. Installation of differential safety cut-outs is recommended to prevent damage due to phase failure.

ELECTRICAL CONNECTIONS (YCAA-B Models 60 -150 Optional ISN Control)

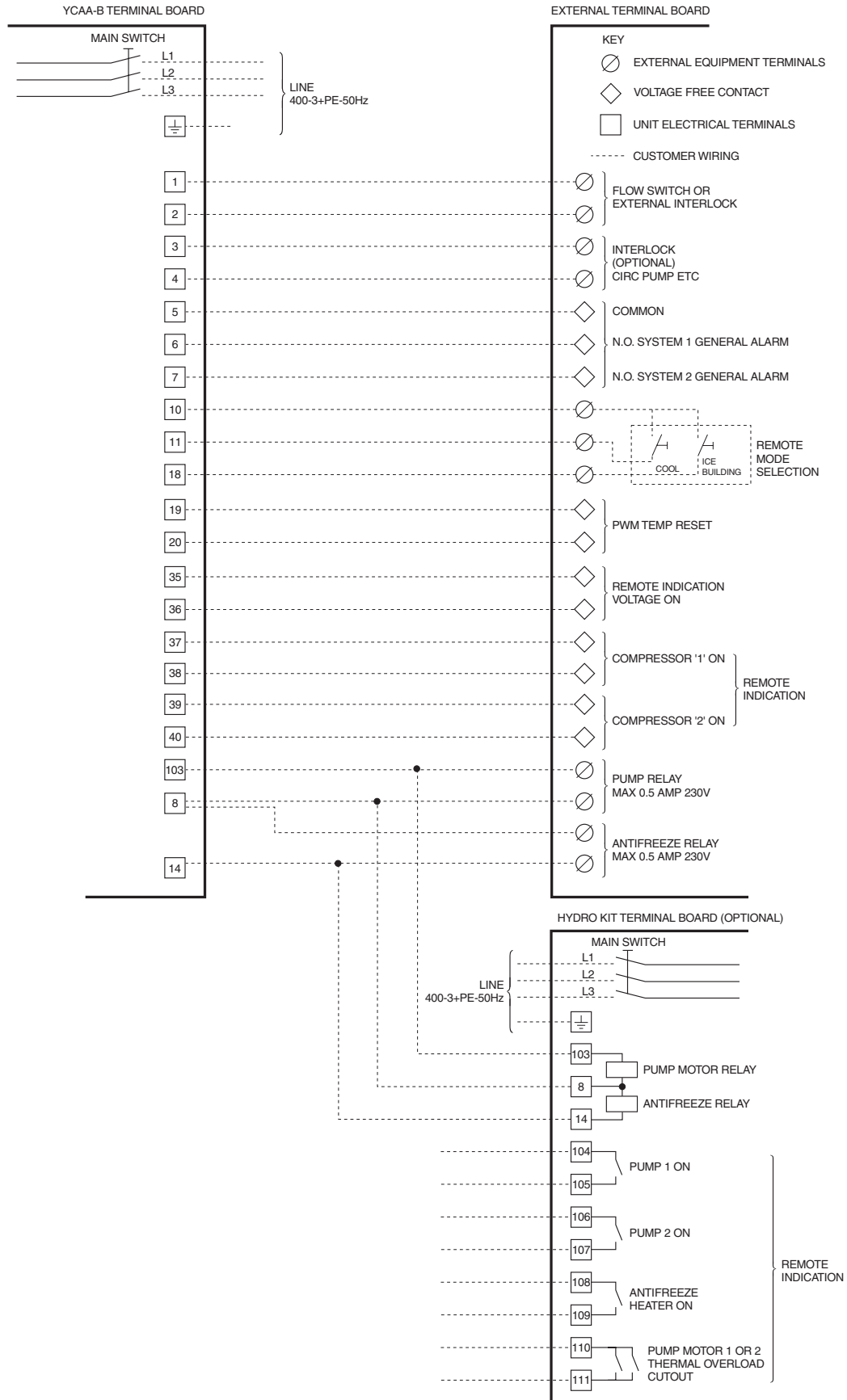

The following connections are required:

- One 400-3-50 Hz supply plus earth.
- Control interlocks if required.

The power connections and interlocks can be made to a single terminal strip. Supply cables should enter the unit via a hole provided.

Mains isolator switches should be located adjacent to the unit and should incorporate provision for locking in the off position. Installation of differential safety cut-outs is recommended to prevent damage due to phase failure.

ELECTRICAL CONNECTIONS (YCAA-B Models 170 -210 Standard ISN Control)

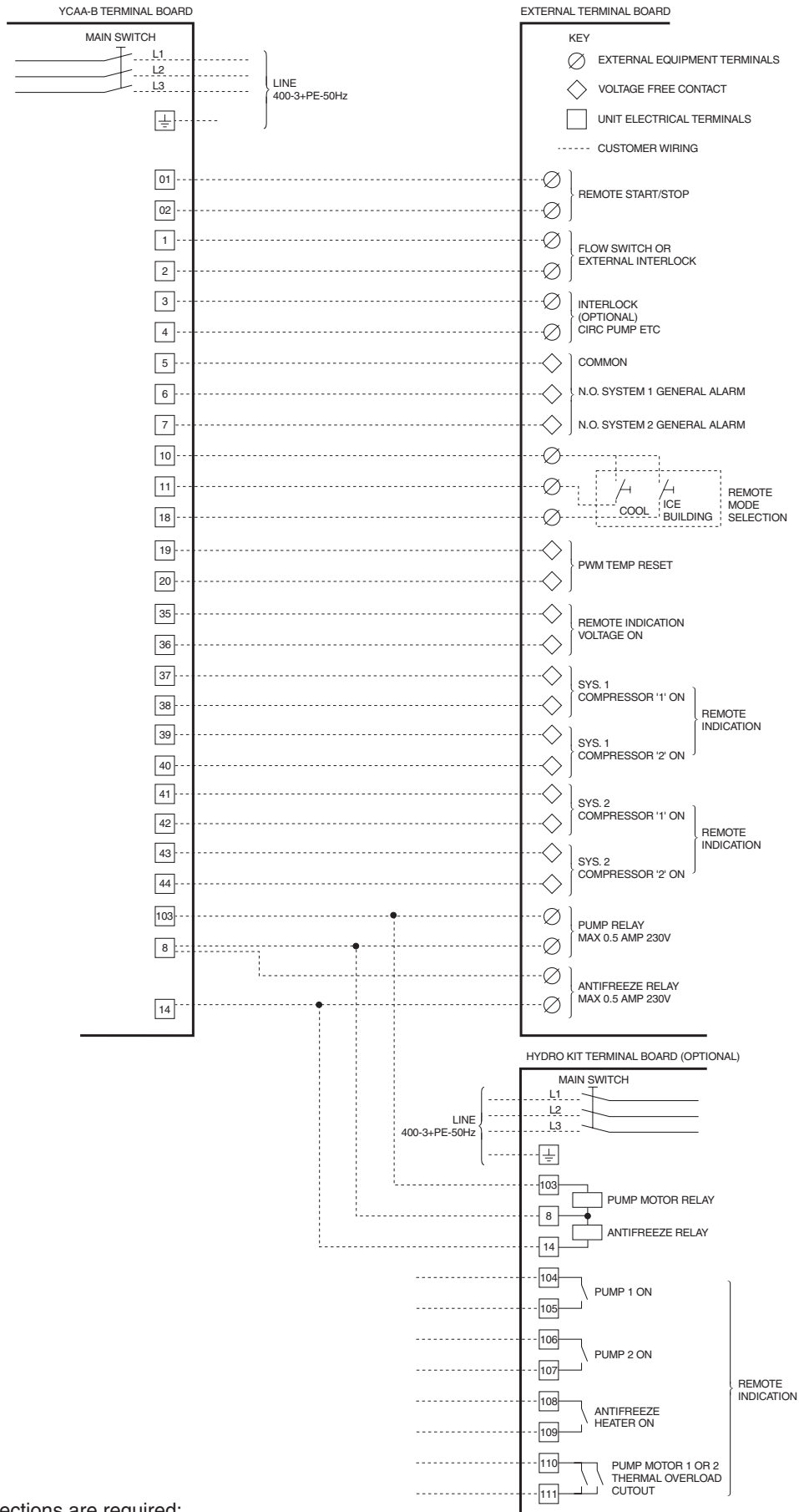

The following connections are required:

- One 400-3-50 Hz supply plus earth.
- Control interlocks if required.

The power connections and interlocks can be made to a single terminal strip. Supply cables should enter the unit via a hole provided.

Mains isolator switches should be located adjacent to the unit and should incorporate provision for locking in the off position. Installation of differential safety cut-outs is recommended to prevent damage due to phase failure.

DIMENSIONS

YCAA-B Models 60, 75, L90 and L105

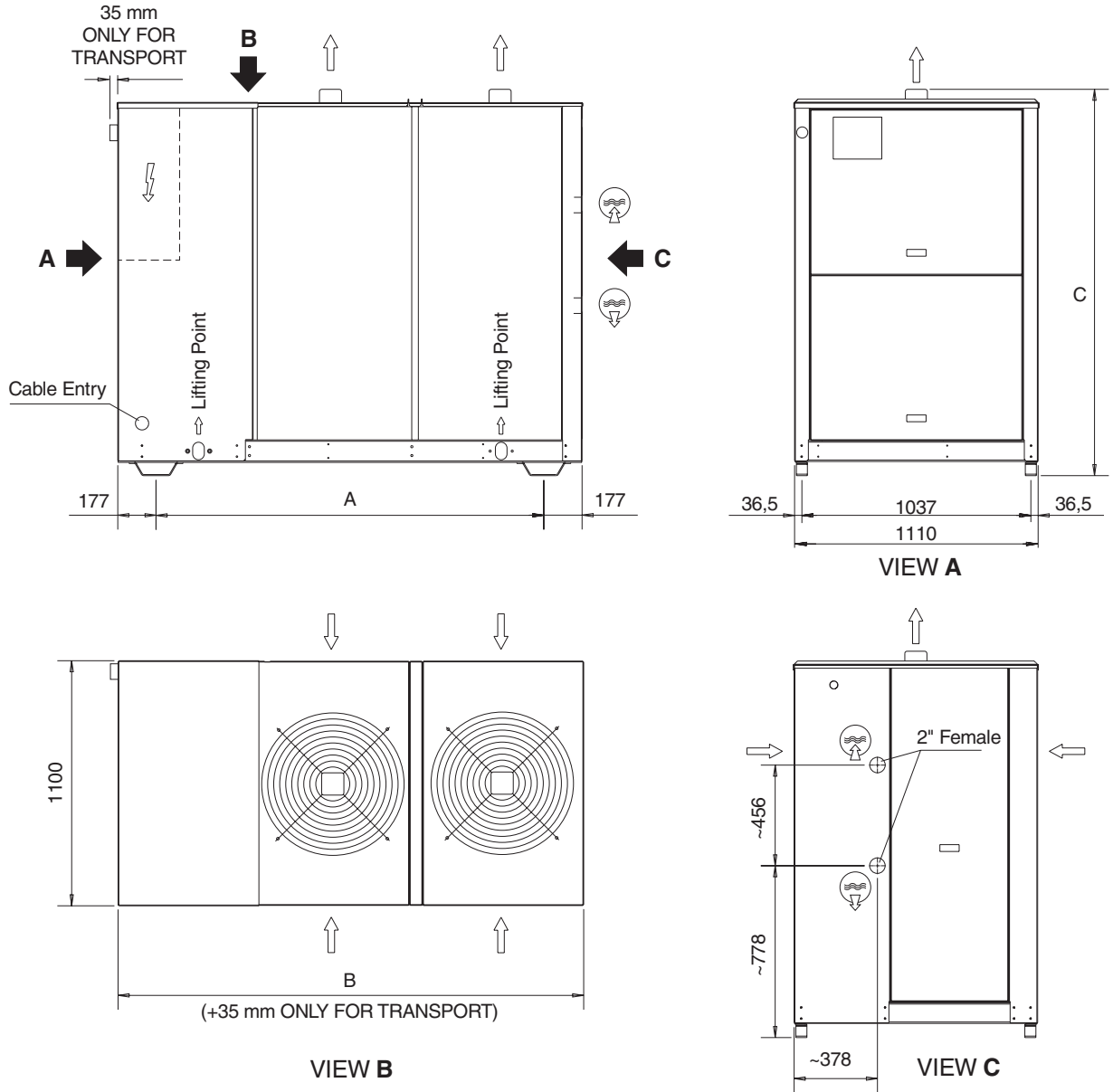

MODEL	VERSION	DIMENSION 'A' (mm)	DIMENSION 'B' (mm)	DIMENSION 'C' (mm)	NUMBER OF FANS
YCAA-B 60	STANDARD	1756	2110	1750	2
	LOW NOISE	1756	2110	1850	2
	HIGH TEMPERATURE	1756	2110	1750	2
YCAA-B 75	STANDARD	1756	2110	1750	2
	LOW NOISE	1756	2110	1850	2
	HIGH TEMPERATURE	1756	2110	1750	2
YCAA-B L90	STANDARD	1756	2110	1750	2
	LOW NOISE	1756	2110	1850	2
	HIGH TEMPERATURE	1756	2110	1850	2
YCAA-B L105	STANDARD	1756	2110	1750	2
	LOW NOISE	1756	2110	1850	2
	HIGH TEMPERATURE	1756	2110	1850	2

DIMENSIONS

YCAA-B Models 120 and 150

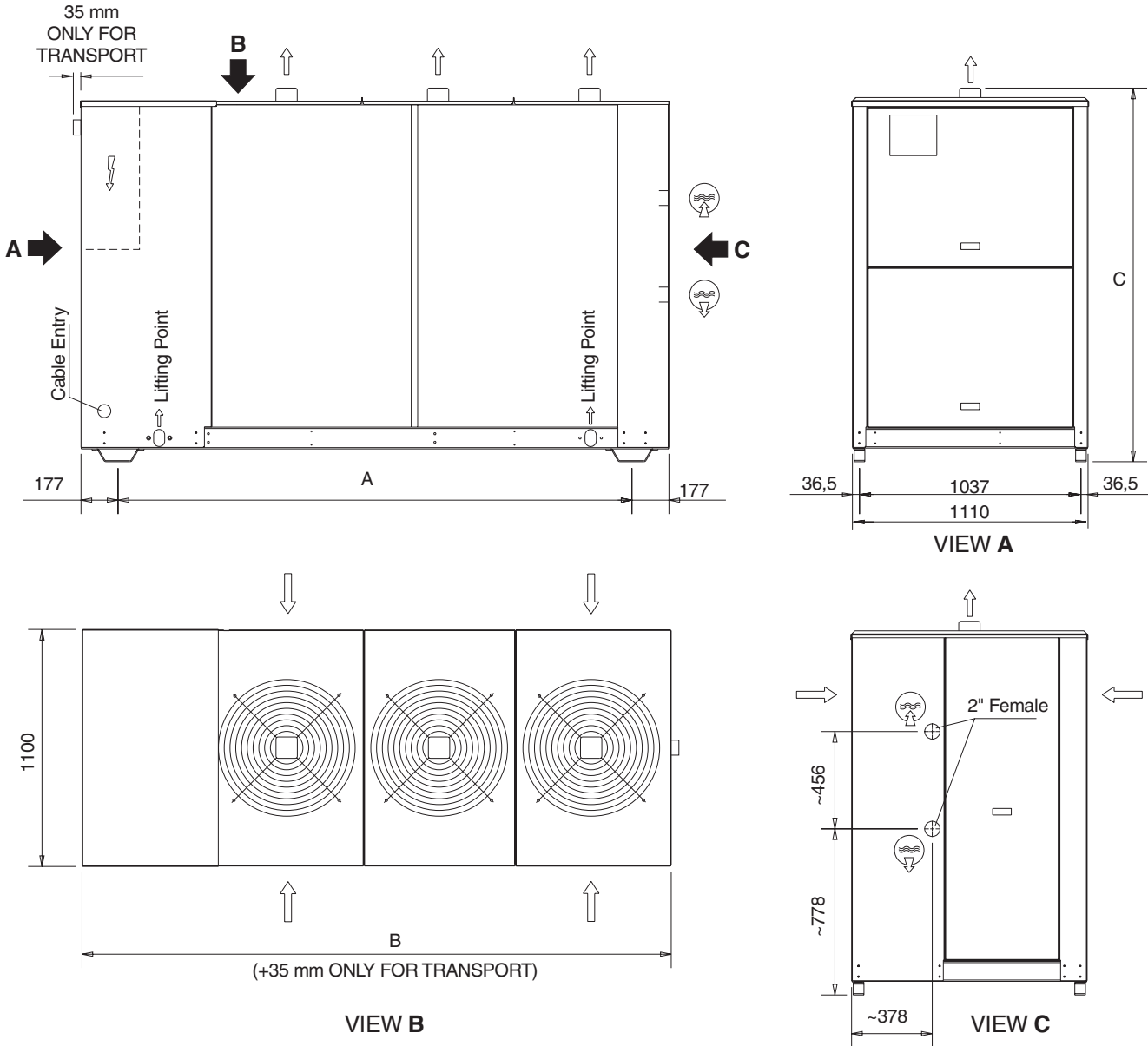

MODEL	VERSION	DIMENSION 'A' (mm)	DIMENSION 'B' (mm)	DIMENSION 'C' (mm)	NUMBER OF FANS
YCAA-B 120	STANDARD	2406	2760	1750	3
	LOW NOISE	2406	2760	1850	3
	HIGH TEMPERATURE	2406	2760	1850	3
YCAA-B 150	STANDARD	2406	2760	1750	3
	LOW NOISE	2406	2760	1850	3
	HIGH TEMPERATURE	2406	2760	1850	3

DIMENSIONS (continued)

YCAA-B Models 170, 190 and 210

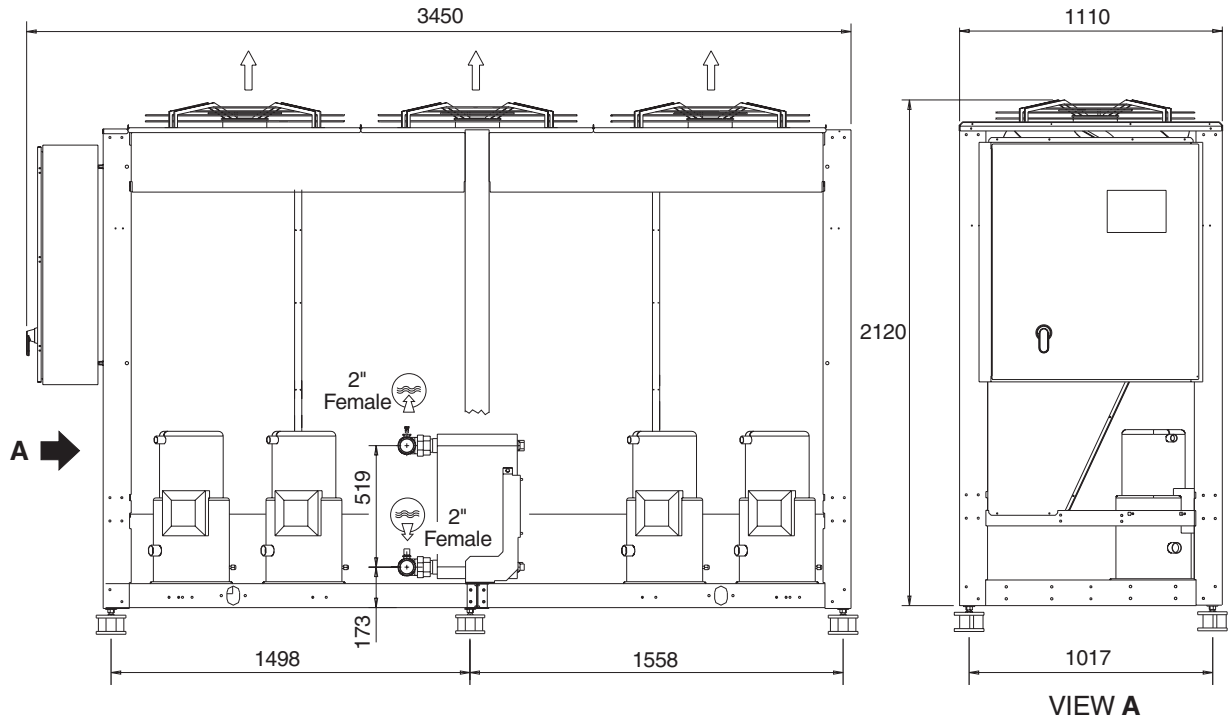

SPACE REQUIREMENTS

Single Unit Applications

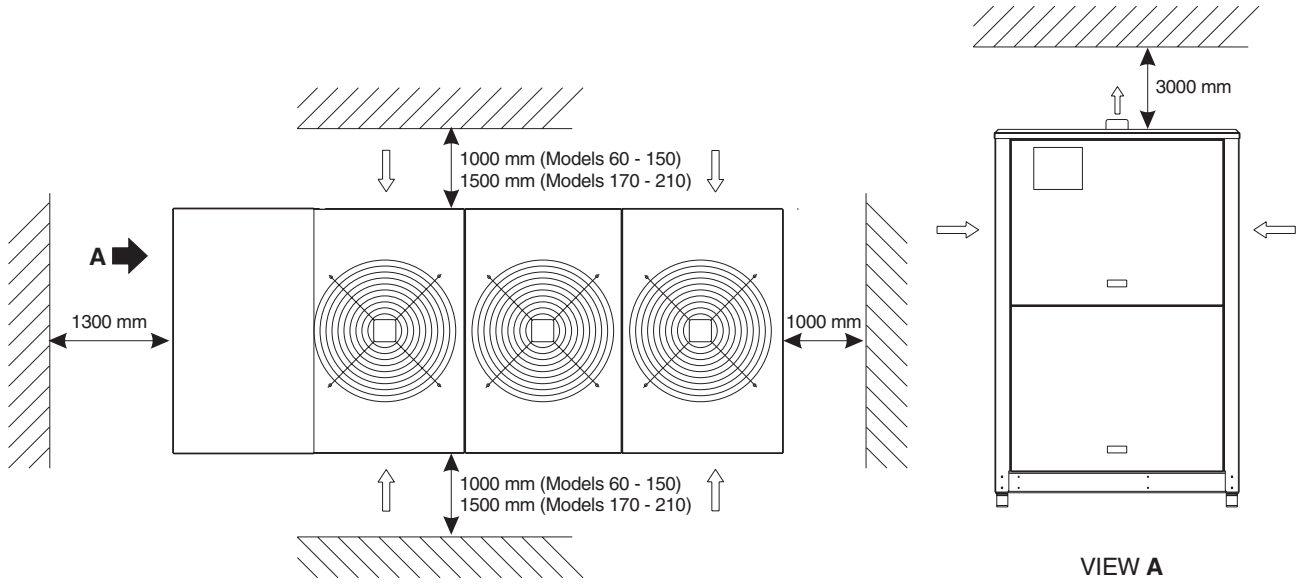

Multi Unit Applications

